



# SRA 150

MOTORIZED GLASS ROOF SYSTEM

# SRA 150

MOTORIZED GLASS ROOF SYSTEM

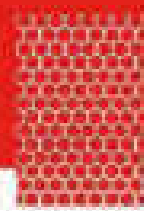

ACCURACY

HARMONY

BALANCE

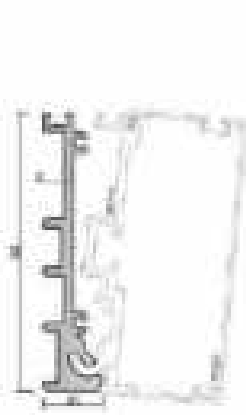

580-1204 ( 1,450 kg/ml )  
SRA150-1204 ÇUKUR BİRİM PROFİLİ

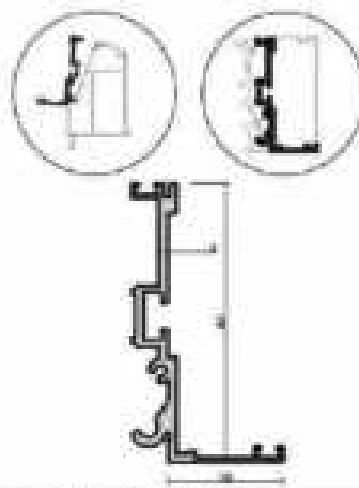

580-5102 ( 1,373 kg/ml )  
SRA150-5102 A10 AÇI BİRİM PROFİLİ



580-5103 ( 0,562 kg/ml )  
SRA150-5103 ÇUKUR BİRİM PROFİLİ



580-5201 ( 1,019 kg/ml )  
SRA150-5201 KAPAK PROFİLİ



580-6107 ( 0,085 kg/ml )  
KAMİL KAPAMA ÇİTAĞI

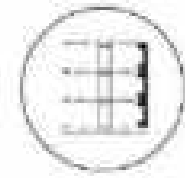

580-7201 ( 0,225 kg/ml )  
SRA150-7201 YUKUKAPAK PROFİLİ

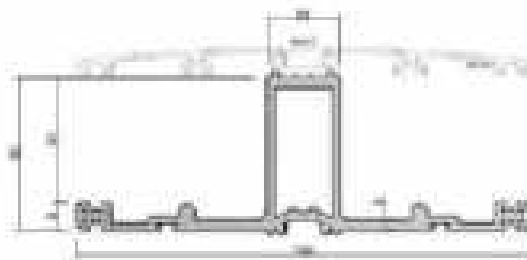

580-1201 ( 1,887 kg/ml )  
SRA150-1201 DİŞLİ BİRİM PROFİLİ

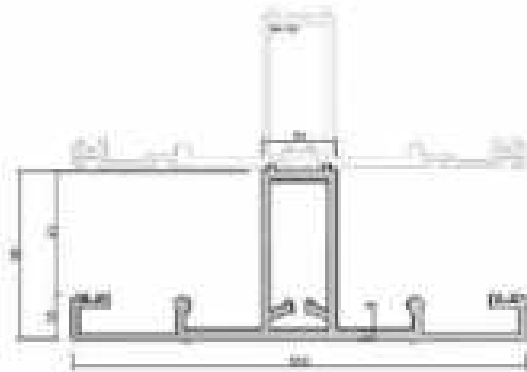

580-1202 ( 2,306 kg/ml )  
SRA150-1202 ALT BİRİM PROFİLİ

# SRA 150

MOTORIZED GLASS ROOF SYSTEM

ACCURACY

HARMONY

BALANCE

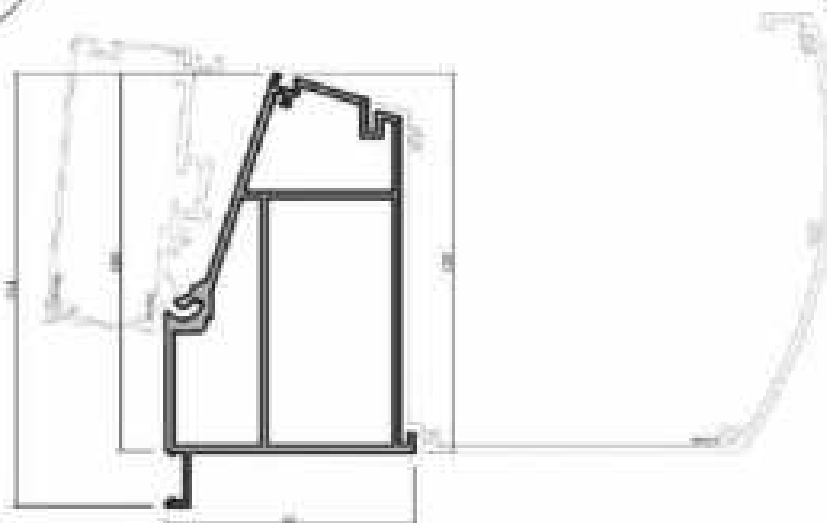

880.2101 ( 3,438 kg/ml )  
GRAIN 121 (20R) PROFIL

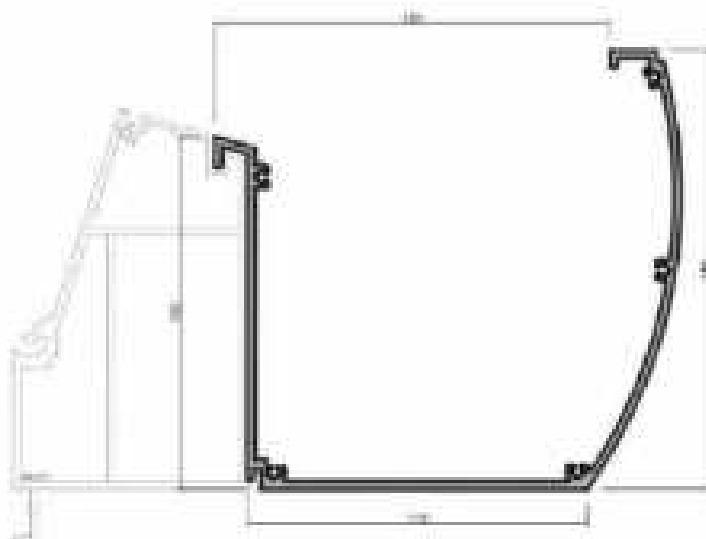

880.3101 ( 3,070 kg/ml )  
GRAIN 100 (20R) PROFIL

# SRA 150

MOTORIZED GLASS ROOF SYSTEM

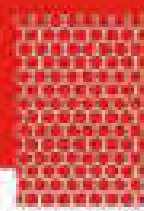

ACCURACY

HARMONY

BALANCE

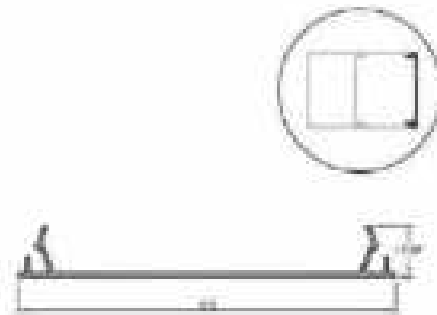
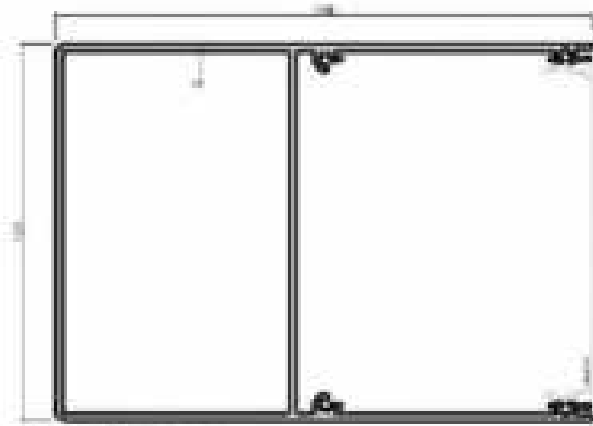

520-1100 ( 4,099 kg/m )  
TAŞIYICI DİREK PROFİLİ

520-8100 ( 0,880kg/m )  
KAPAK PROFİLİ

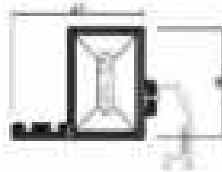
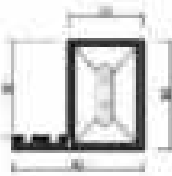

580-4201 ( 0,613 kg/m )  
SRA150 M02 KANAL PROFİLİ

580-4202 ( 0,683 kg/m )  
SRA150 KANAL PROFİLİ

580-6200 ( 0,250kg/m )  
DAMALIK

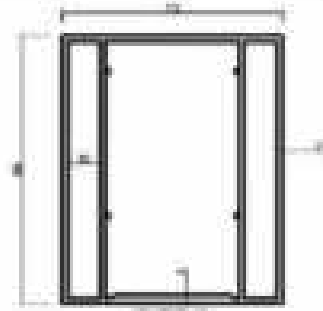

580-5102 ( 0,520 kg/m )  
DAMALIK ADAPTOR PROFİLİ

700-6102 ( 0,110 kg/m )  
KAPAK PROFİLİ



580-6205 ( 0,395 kg/m )  
AKSA 6100 PROFİLİ

700-6103 ( 0,167 kg/m )  
LED KAPAK PROFİLİ

580-1201 ( 2,743 kg/m )  
SRA150 M03 TAŞIYICI DİREK PROFİLİ



580-6101 ( 2,286 kg/m )  
SRA150 HAREKET AKTARMA PROFİLİ

580-6102 ( 1,475 kg/m )  
BAĞLANTI ADAPTOR PROFİLİ

700-6104 ( 0,190 kg/m )  
LED KASA PROFİLİ









# SRA 150

MOTORIZED GLASS ROOF SYSTEM

ACCURACY

HARMONY

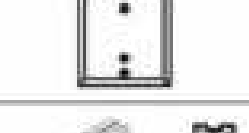
BALANCE

ÜRÜN ÇİZİMİ <i>DRAWING</i>	SİSTEM KOD <i>SYSTEM CODE</i>	ÜRÜNÜN ADI <i>PRODUCT NAME</i>
	3516500	SİSTEM RULMAN
	9516930	SRA150 ÖN DİŞLİ MİL SOL/SAĞ
	9516931	SRA150 ÖN DİŞLİ MİL ORTA
	9516932	SRA150 ARKA DİŞLİ MİL SAĞ/SOL
	9516933	SRA150 ARKA DİŞLİ MİL ORTA
	9516934	SRA150 MOTOR AKTARIM MİLİ
	9803100	KASNAK DİŞLİ
	9801702	KAPAK
	1601513	BAĞLANTI PROFİLİ 100MM
	9501313	20*6 KAMA



# SRA 150

MOTORIZED GLASS ROOF SYSTEM

ACCURACY

HARMONY

BALANCE

ÜRÜN ÇİZİMİ <i>DRAWING</i>	SİSTEM KOD <i>SYSTEM CODE</i>	ÜRÜNÜN ADI <i>PRODUCT NAME</i>
	9503110	8 MM KAYIŞ
	9816300	KAYIŞ KANAT BAĞLANTI
	9516308	M20 MİL SEGMANI DIN471A 20x1,2m A2
	9507101	Ø20MM BURÇ
	9801000	120 NM TUP MOTOR
	9801308	ÖN GERGİ ALT SAĞ SOL
	9801309	ÖN GERGİ TAKIMI ORTA AKSLAR
	9801310	SERVO MOTOR İÇİN ARKA HAREKET MİLİ SAĞ SOL KENAR
	9801311	SERVO MOTOR İÇİN ARKA HAREKET MİLİ ORTA AKSLAR
	9801312	SERVO MOTOR İÇİN ARKA ORTA AKS HAREKET İLETİM

# SRA 150

MOTORIZED GLASS ROOF SYSTEM

ACCURACY

HARMONY

BALANCE

ÜRÜN ÇİZİMİ <i>DRAWING</i>	SİSTEM KOD <i>SYSTEM CODE</i>	ÜRÜNÜN ADI <i>PRODUCT NAME</i>
	9801300	ÇİFT YÖNLÜ TRİGER RULMANI ARKA SET - 4
	9801301	SAG YÖN TRİGER RULMANI ARKA SET - 5
	9801302	SOL YÖN TRİGER RULMANI ARKA SET - 6
	9801303	ÇİFT YÖNLÜ TRİGER RULMANI ARKA SOL SET - 7
	9801304	ÇİFT YÖNLÜ TRİGER RULMANI ARKA SAĞ SET - 8
	9801305	ÇİFT YÖNLÜ TRİGER RULMANI ARKA SAĞ SET - 9
	9801306	TRİGER RULMANI ARKA SOL SET - 10
	9801307	TRİGER RULMANI ARKA SAĞ SET - 11
	9809100	MOTOR KUTU
	9501301	MİL BAĞLANTI APARATI







# SRA 150

MOTORIZED GLASS ROOF SYSTEM

ACCURACY

HARMONY

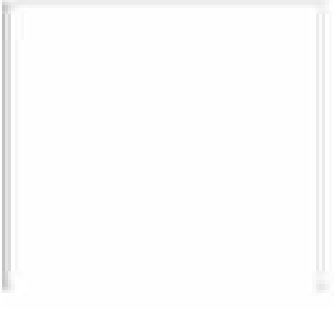
BALANCE

ÜRÜN ÇİZİMİ DRAWING	SİSTEM KOD SYSTEM CODE	ÜRÜNÜN ADI PRODUCT NAME
	5303207	CAM TAKOZU 5x25x80 mm
	5303218	CAM TAKOZU 2x20x80 mm
	9803600	KANAT STOPER PROFİLİ 12,5x12,5 mm
	ÖZEL AKS	2 MM BÜKÜM LEVHA
	1616411	DERE BİRLEŞİM LEVHASI H: 300 MM
	1616412	MOTOR KUTU LEVHA ALT 1,0 mt
	1616413	MOTOR KUTU LEVHA ALT 1,25 mt
	1616414	MOTOR KUTU LEVHA ALT 1,50 mt
	7599222	CAMLAMA BANTI 15*2 MM
	7605502	SOUDAL FIX HIGHTACK 290 ML



# SRA 150

MOTORIZED GLASS ROOF SYSTEM

ACCURACY

HARMONY

BALANCE

ÜRÜN ÇİZİMİ <i>DRAWING</i>	SİSTEM KOD <i>SYSTEM CODE</i>	ÜRÜNÜN ADI <i>PRODUCT NAME</i>
	3202516	GÖLGELENDİRME SIZDIRMAZLIK FİTİLİ
	3202127	İÇ CAM FİTİLİ
	17.150.10.20.195G	FİTİL DERZ DOLGU 10MM (900MT)
	3226501	FLOKLU FİTİL
	3203009	FİTİL KİL 6,7*500 MM
	7589228	ÇİFT TARAFLI YAPIŞKAN BANT 1,5*15 MM
	9801700	ARKA BİTİŞ KAPAK
	9801701	ÖN OLUK KAPAK
	9808300	KOLON ÜST BAĞLANTI
	9808301	KOLON ALT BAĞLANTI
	8003601	SÜZGEÇ 70MM





# SRA 150

MOTORIZED GLASS ROOF SYSTEM

ACCURACY

HARMONY

BALANCE

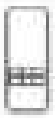
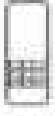
ÜRÜN ÇİZİMİ <i>DRAWING</i>	SİSTEM KOD <i>SYSTEM CODE</i>	ÜRÜNÜN ADI <i>PRODUCT NAME</i>
	1601512	U BAĞLANTI 46,5MM
	1601514	U BAĞLANTI 46,5MM
	1501105	3,9*32 YHB
	1501109	4,2*45YHB
	1501201	SAC VİDASI YHB 4,8*32
	1501614	CIVATA M10*100
	1210-325	KÖŞE TAKOZU
	9501104	KUMANDA 1KANAL EC541-11
	9501101	KUMANDA 5KANAL EC545-11
	9501108	KUMANDA 10KANAL EC5410-11

# SRA 150

MOTORIZED GLASS ROOF SYSTEM

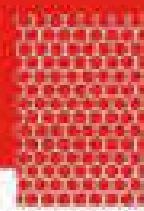

ACCURACY

HARMONY

BALANCE

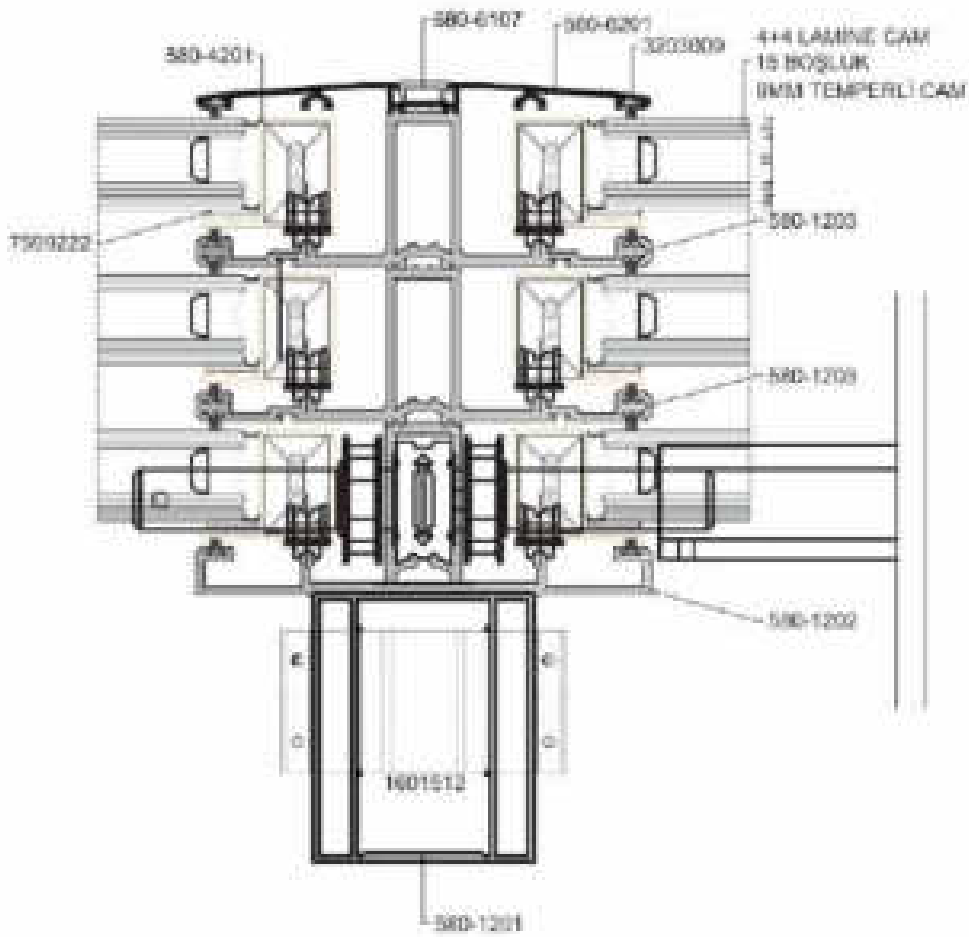

# SRA 150

MOTORIZED GLASS ROOF SYSTEM

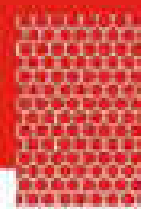

ACCURACY



HARMONY



BALANCE

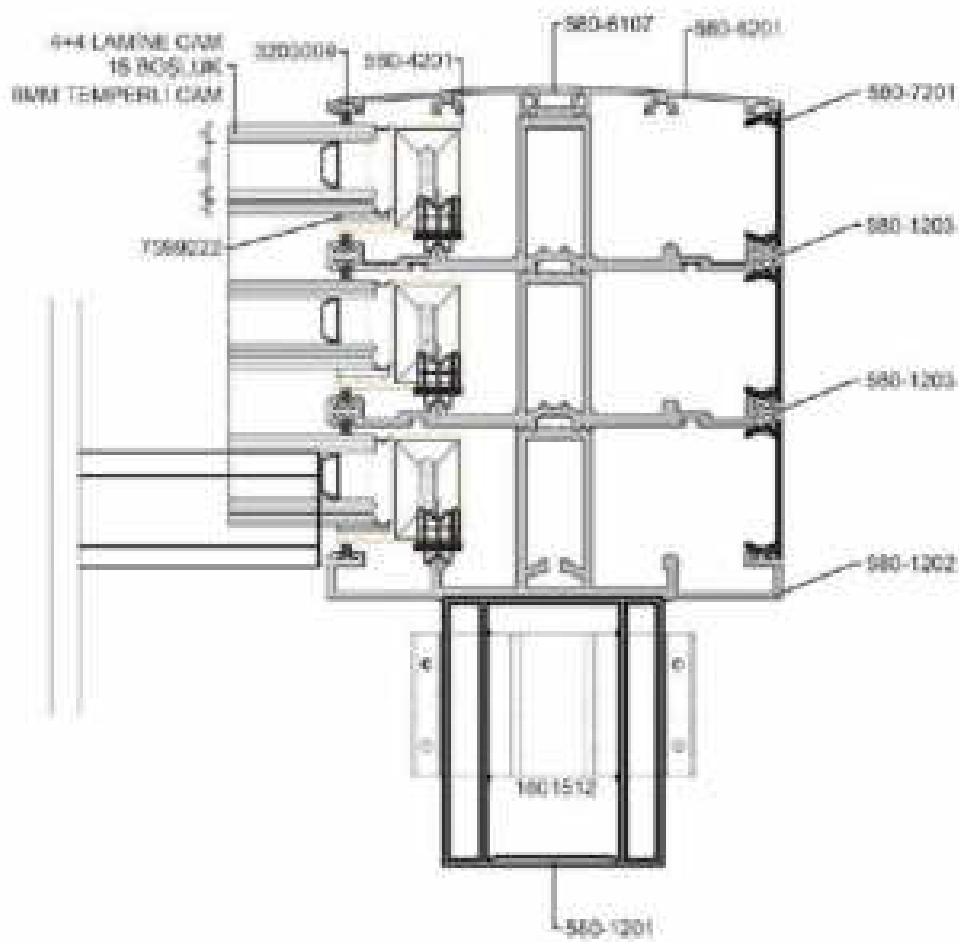

# SRA 150

MOTORIZED GLASS ROOF SYSTEM

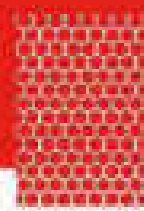

ACCURACY

HARMONY

BALANCE

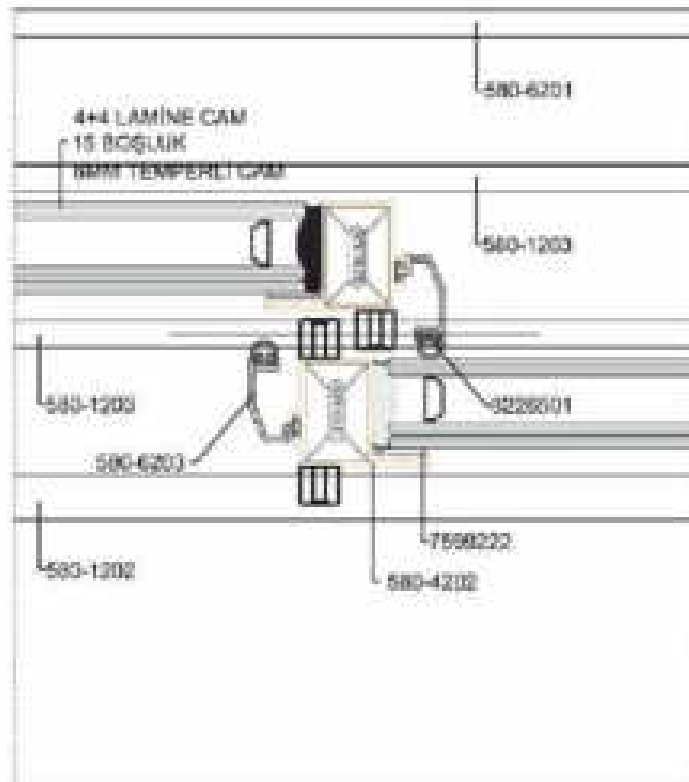
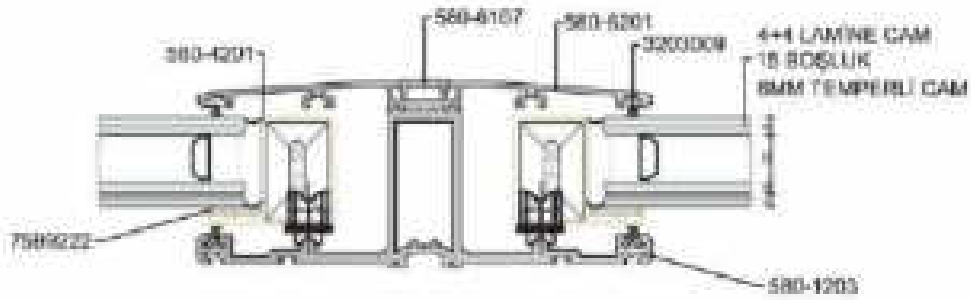

# SRA 150

MOTORIZED GLASS ROOF SYSTEM

ACCURACY

HARMONY

BALANCE

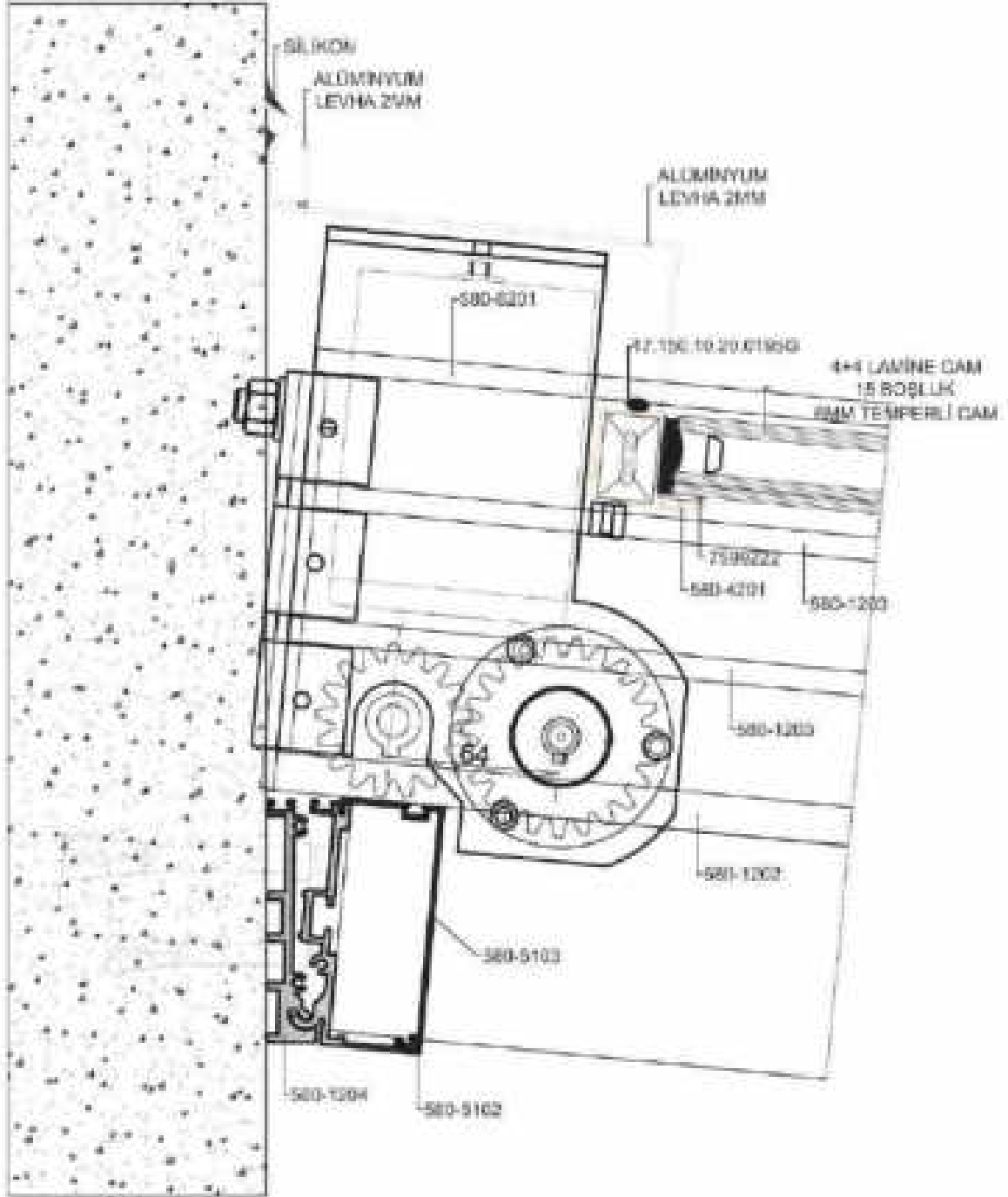

Servo Motor Detayı  
Genişlik 4000mm sonrası için kullanılacaktır.

# SRA 150

MOTORIZED GLASS ROOF SYSTEM

ACCURACY

HARMONY

BALANCE

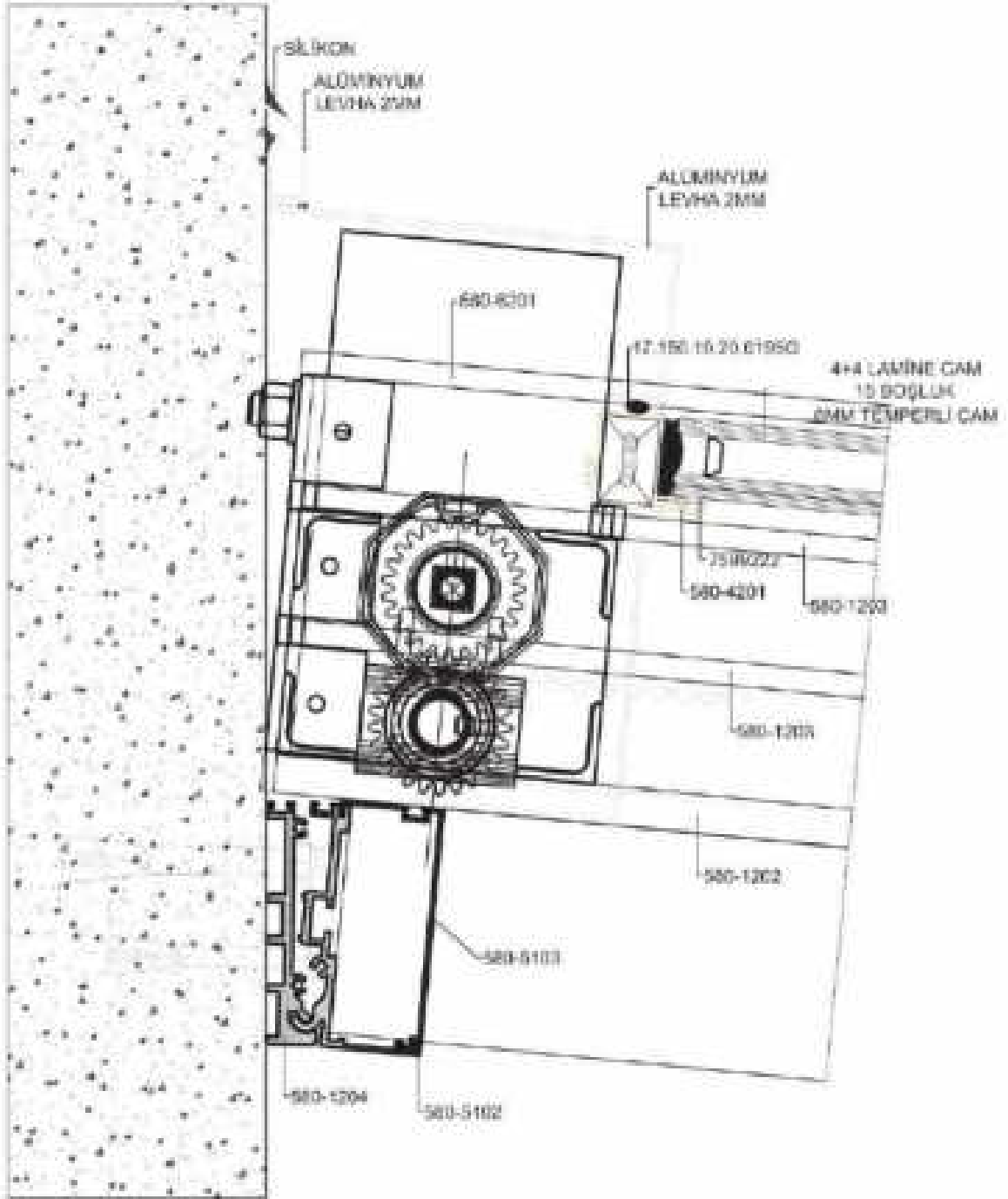

Tüp Motor Detayı  
Genişlik 4000mm 'e kadar kullanılabilir.

# SRA 150

MOTORIZED GLASS ROOF SYSTEM

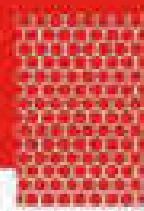

ACCURACY



HARMONY



BALANCE

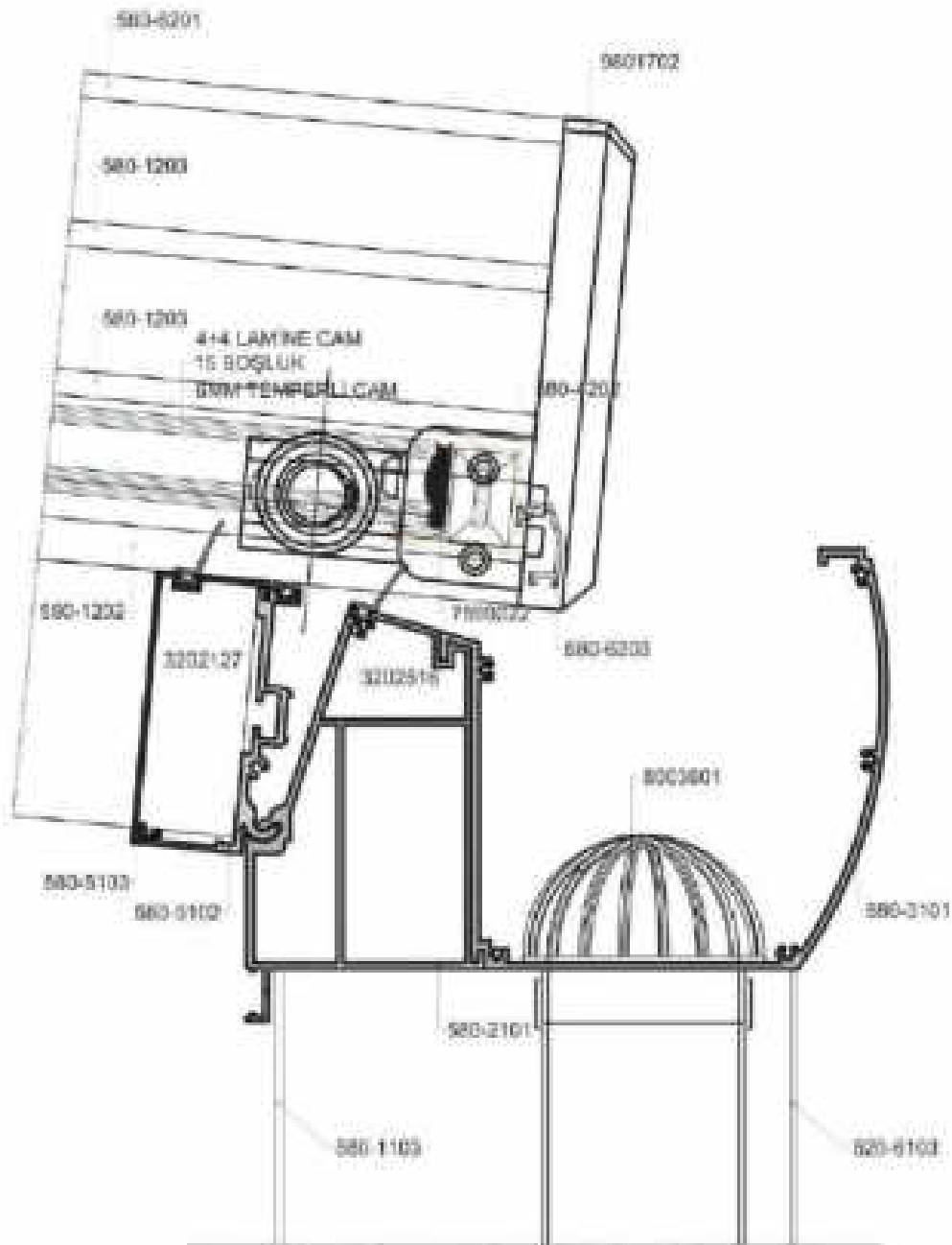



# SRA 150

MOTORIZED GLASS ROOF SYSTEM

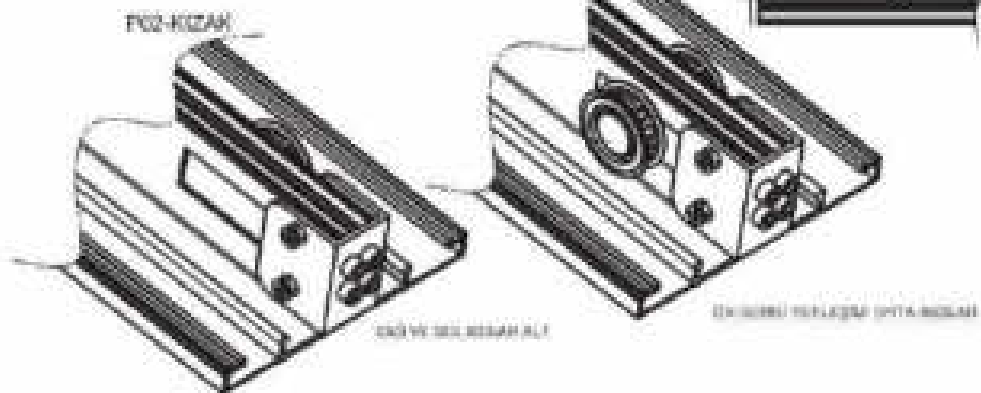
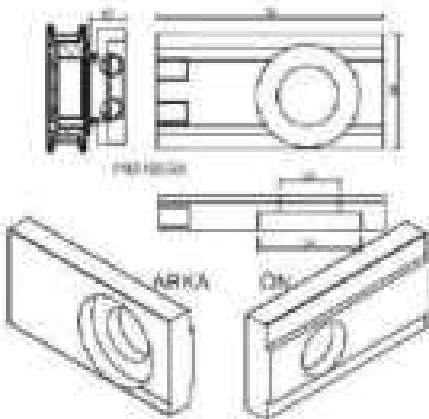
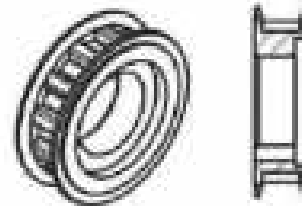
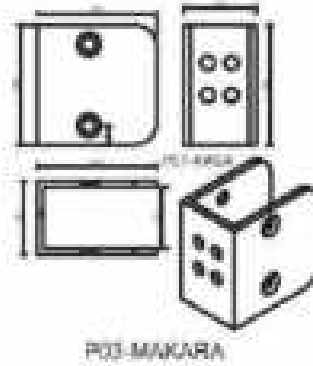
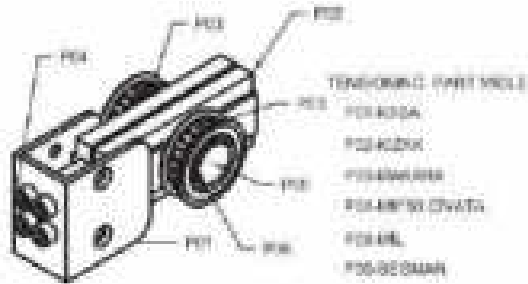



# SRA 150

MOTORIZED GLASS ROOF SYSTEM

ACCURACY

HARMONY

BALANCE

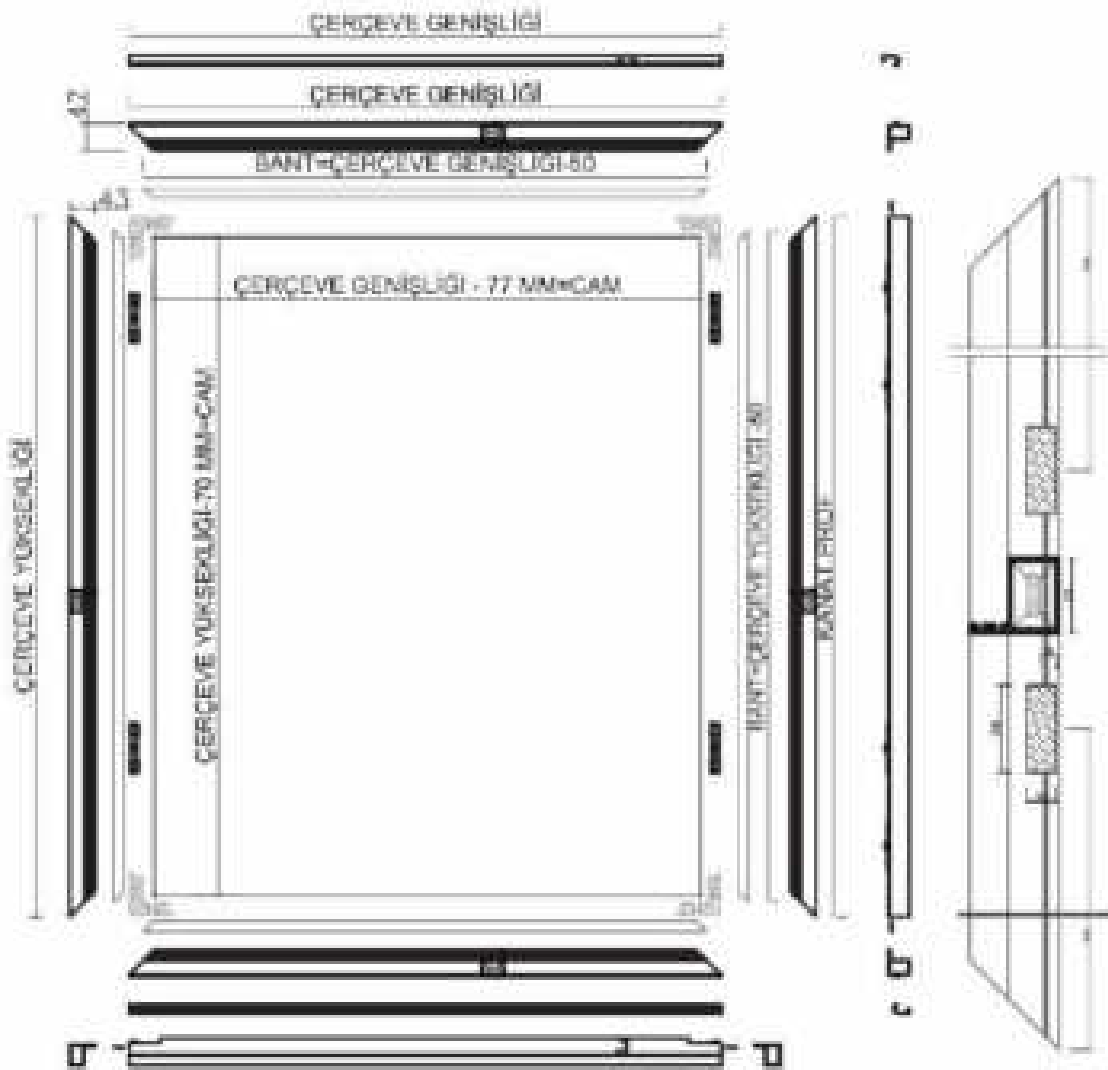

# SRA 150

MOTORIZED GLASS ROOF SYSTEM

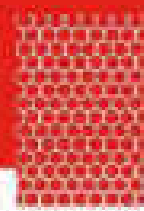

ACCURACY



HARMONY



BALANCE

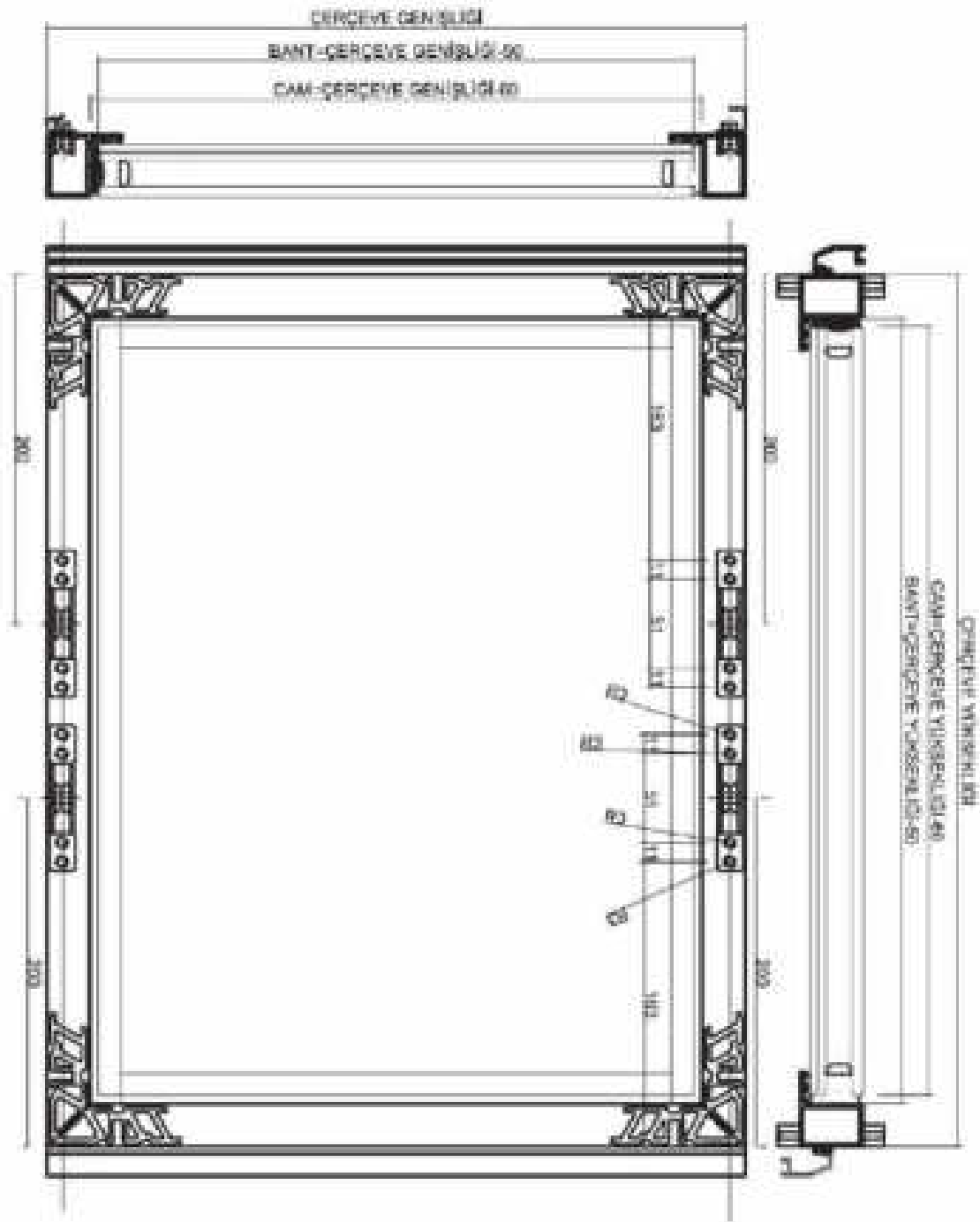

# SRA 150

MOTORIZED GLASS ROOF SYSTEM

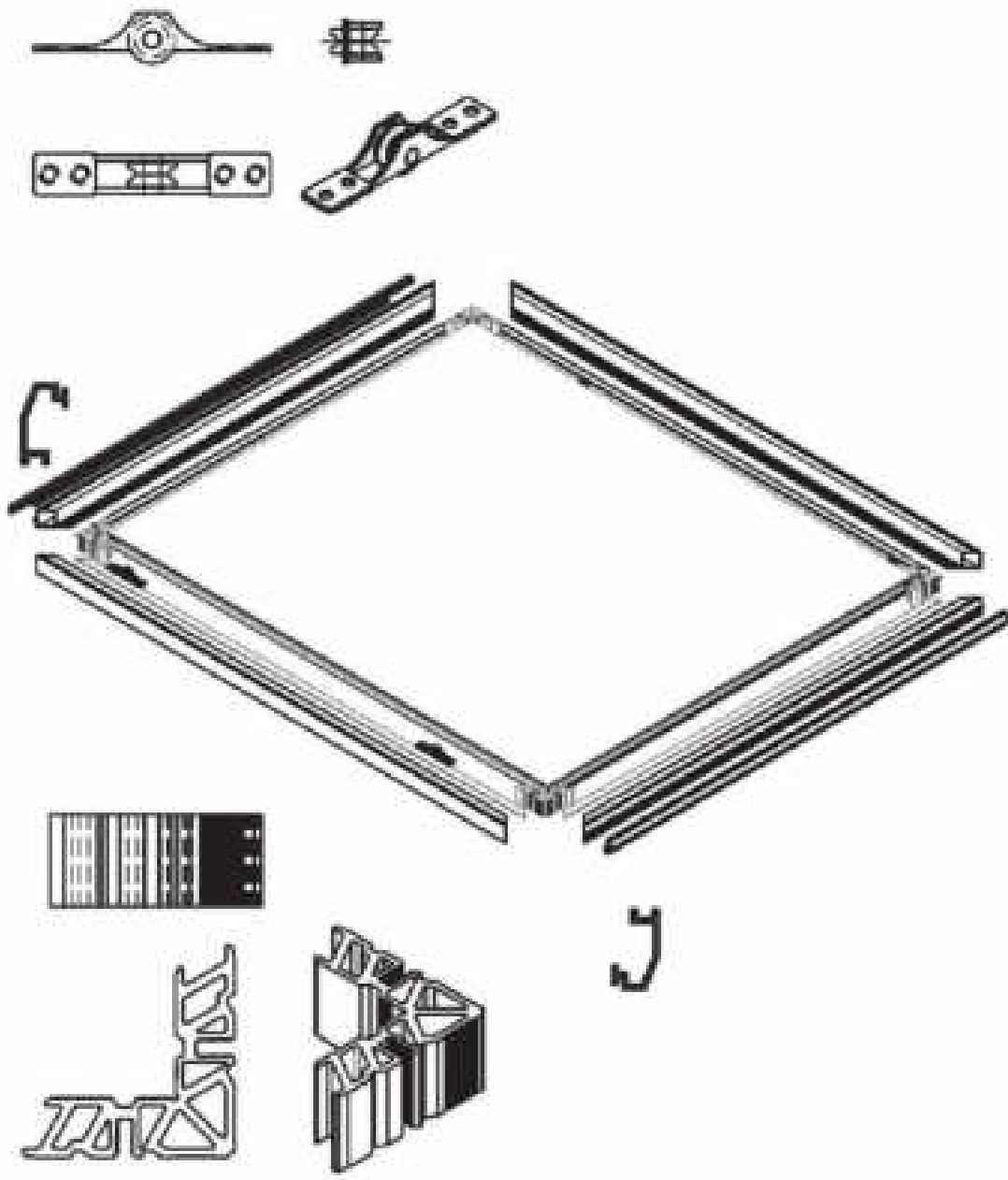

# SRA 150

MOTORIZED GLASS ROOF SYSTEM

ACCURACY

HARMONY

BALANCE

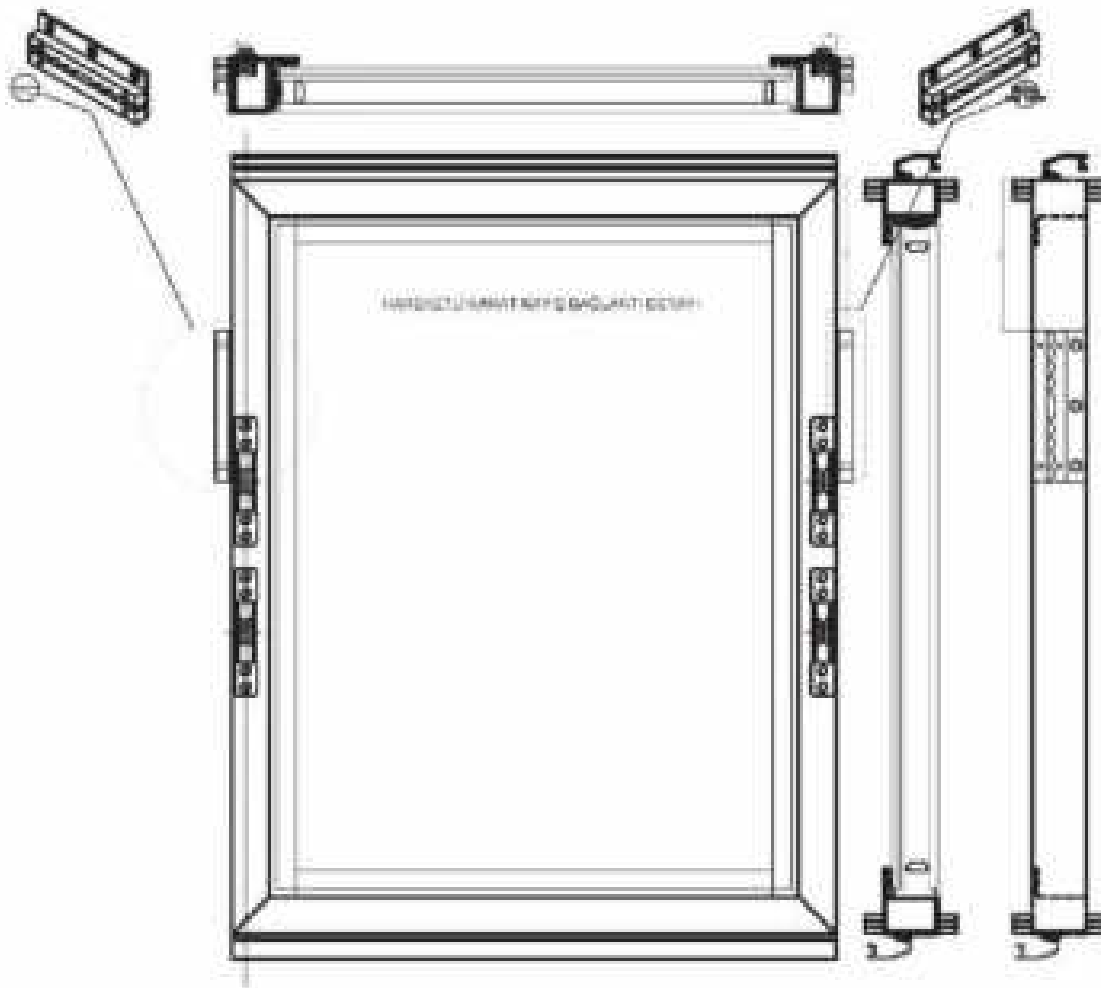

# SRA 150

MOTORIZED GLASS ROOF SYSTEM

ACCURACY

HARMONY

BALANCE

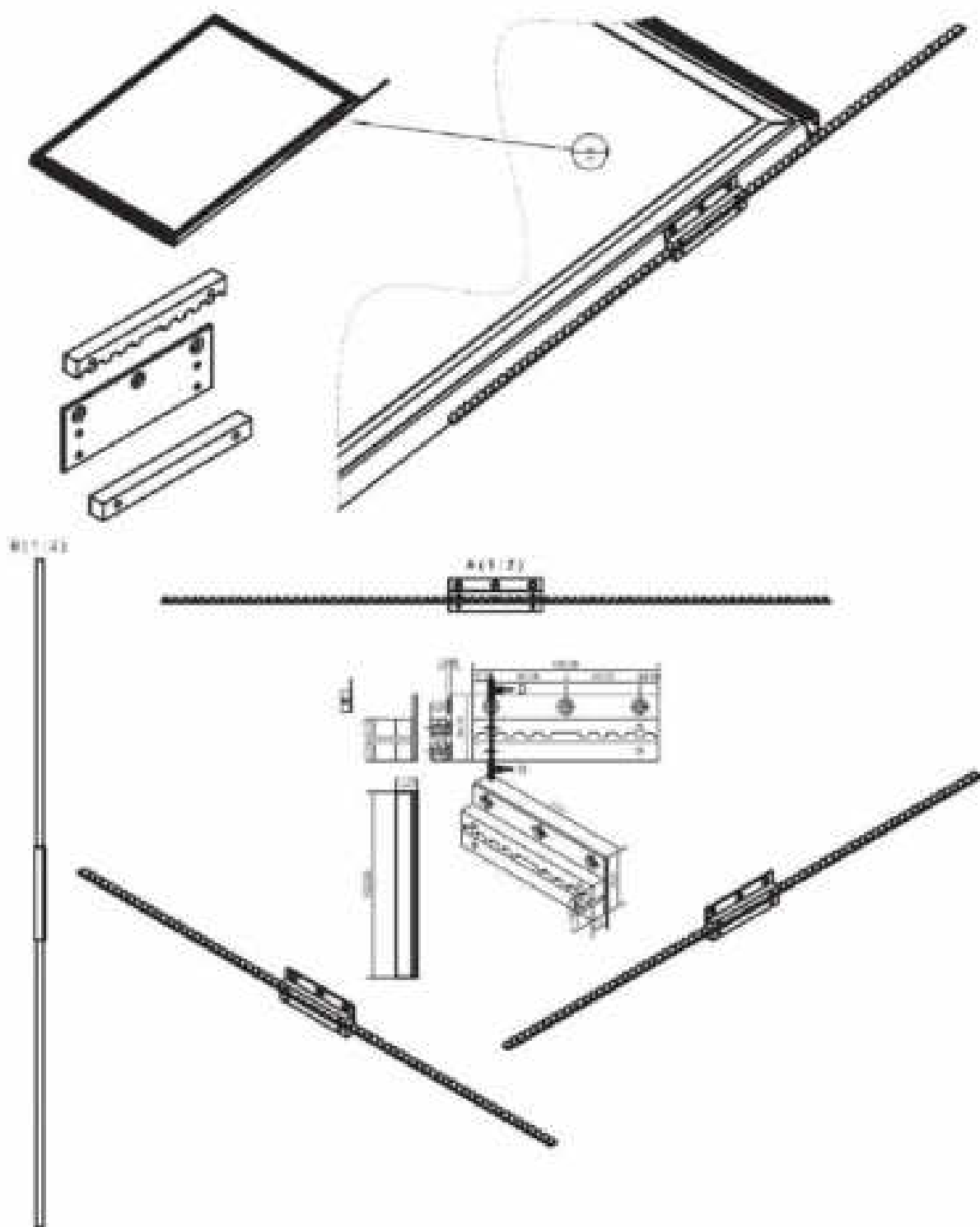

# SRA 150

MOTORIZED GLASS ROOF SYSTEM

ACCURACY

HARMONY

BALANCE

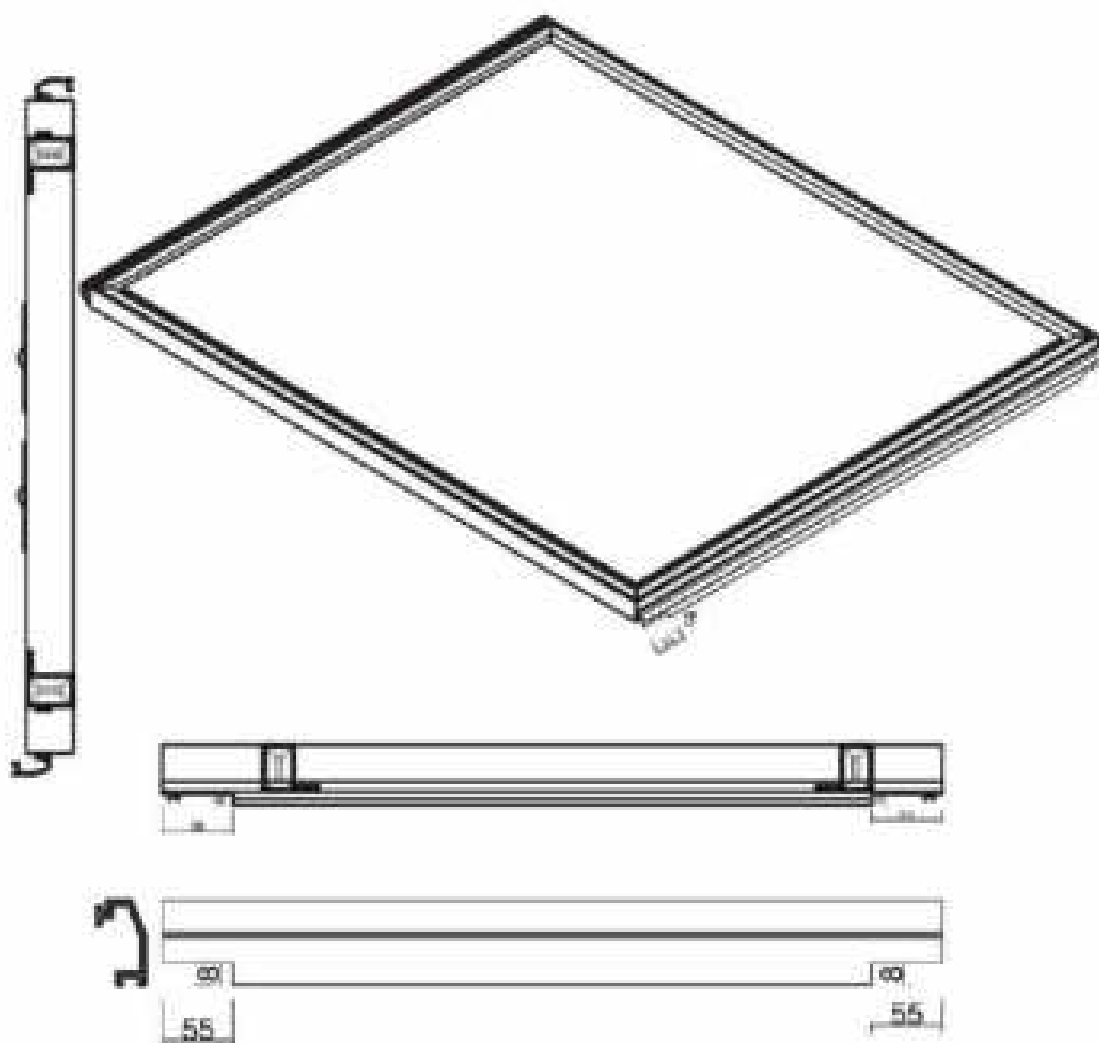



# SRA 150

MOTORIZED GLASS ROOF SYSTEM

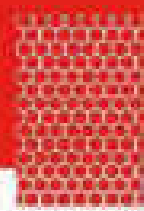

ACCURACY



HARMONY



BALANCE

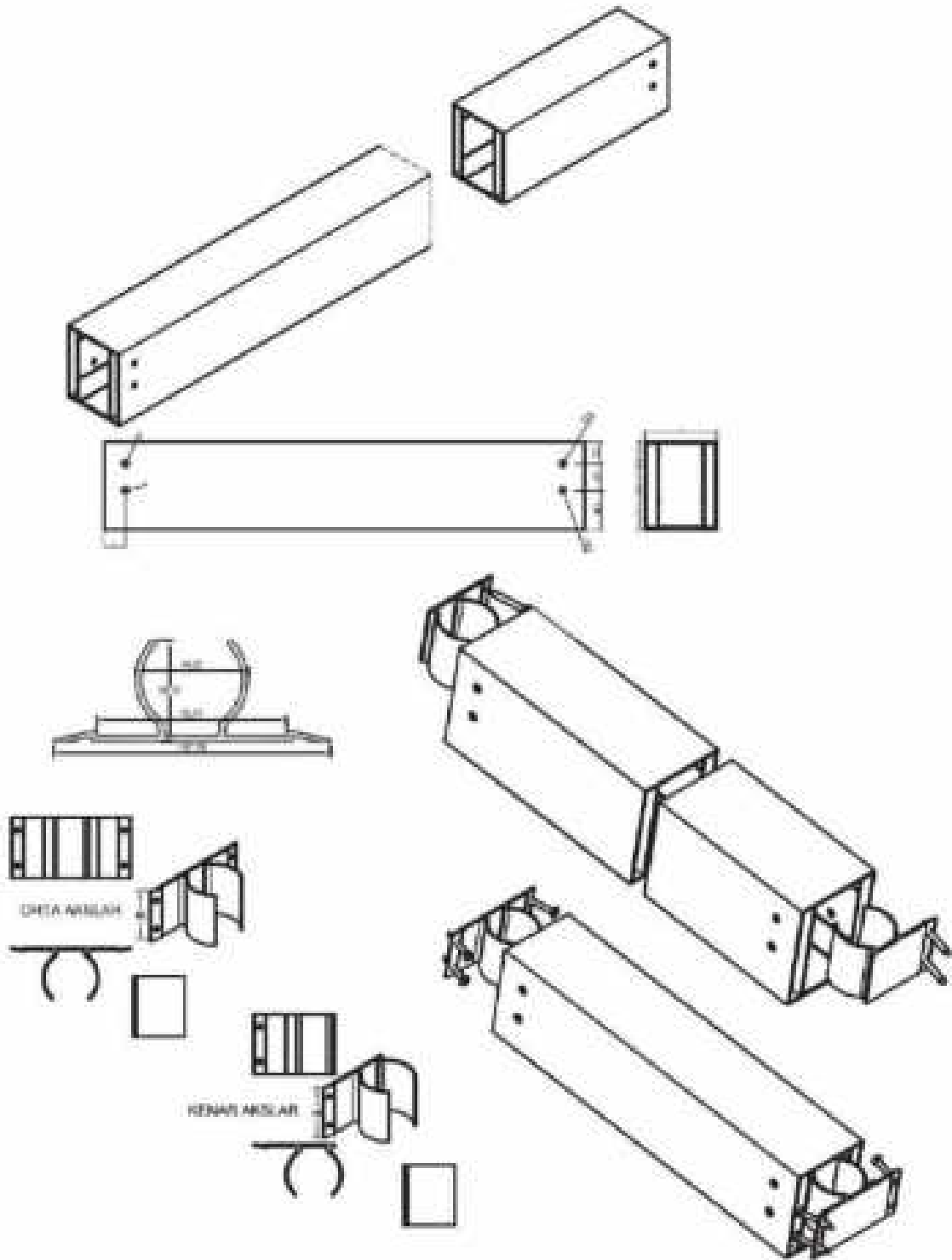

# SRA 150

MOTORIZED GLASS ROOF SYSTEM

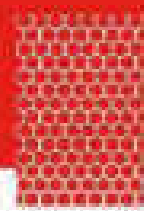

ACCURACY



HARMONY



BALANCE

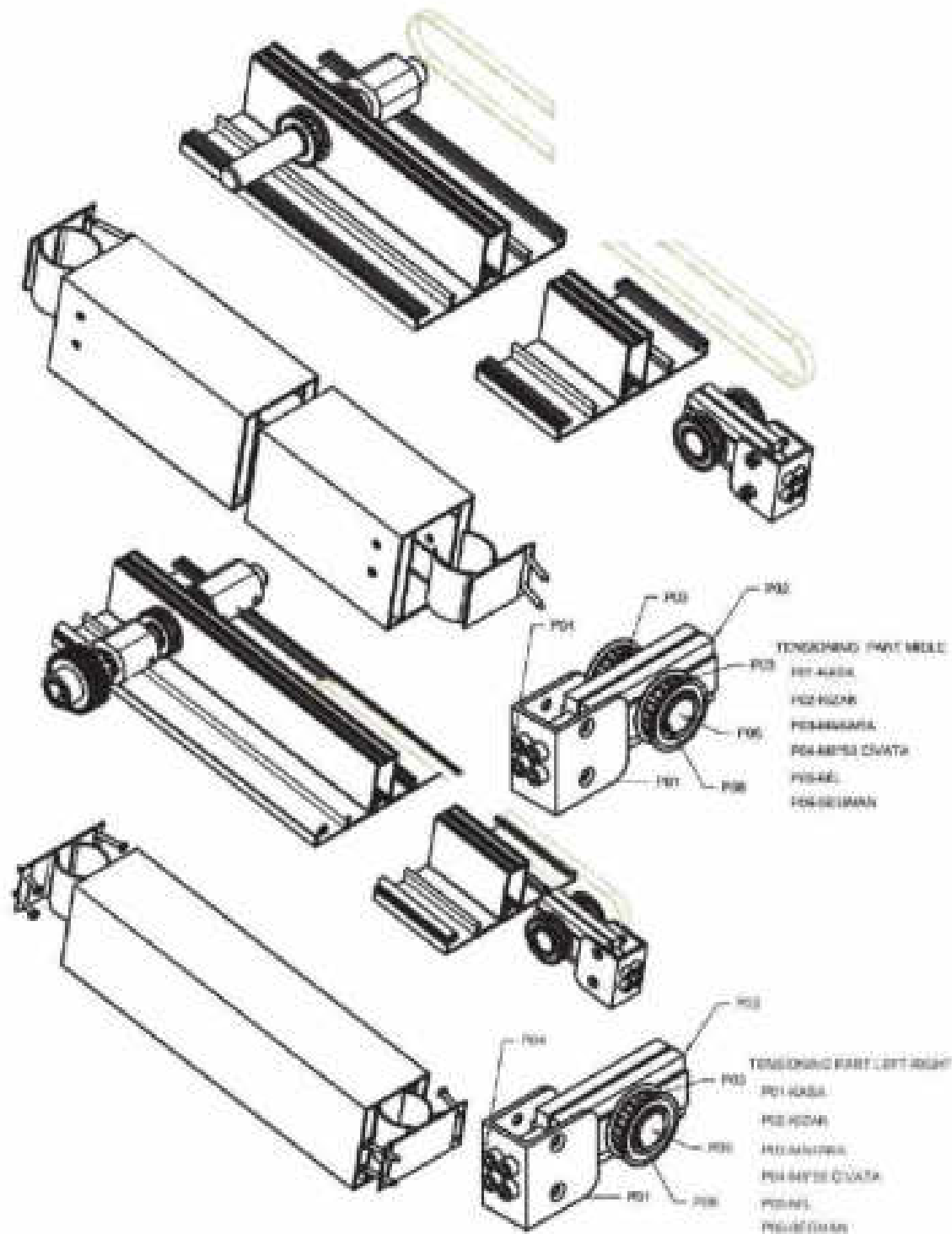

# SRA 150

MOTORIZED GLASS ROOF SYSTEM

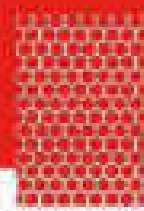

ACCURACY



HARMONY



BALANCE



120 NM TUBULAR MOTOR DETAILS

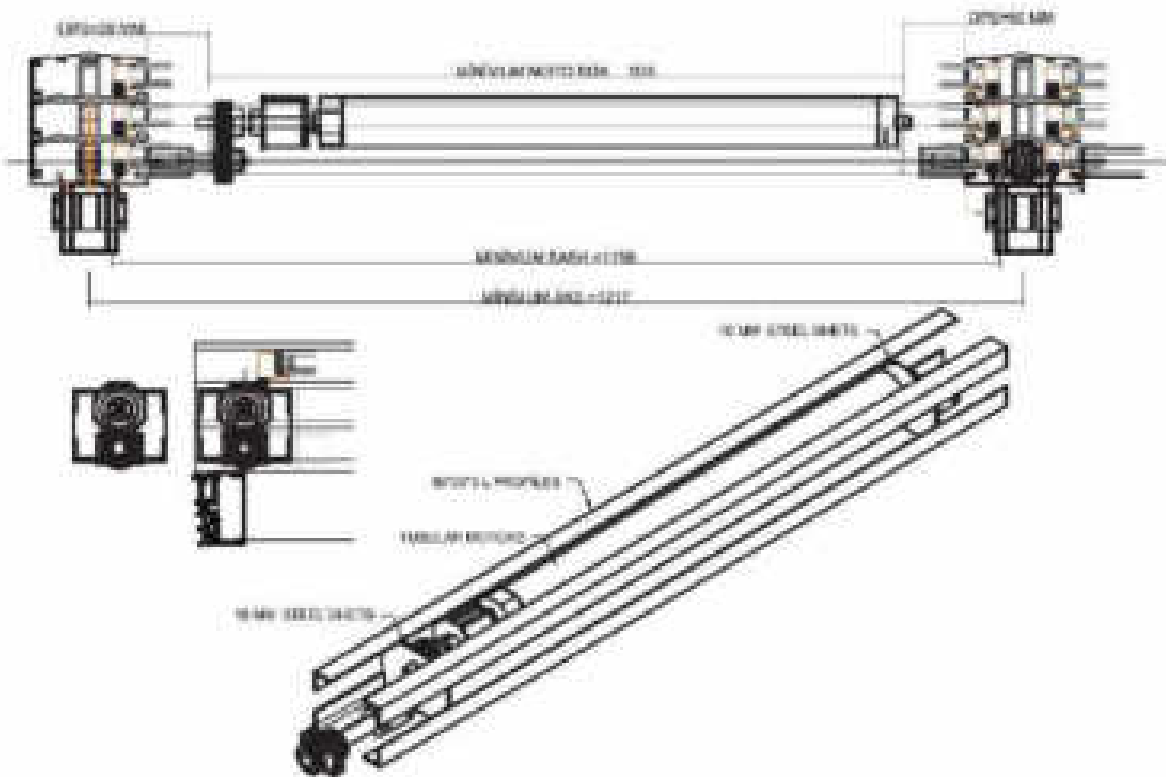

# SRA 150

MOTORIZED GLASS ROOF SYSTEM

ACCURACY

HARMONY

BALANCE

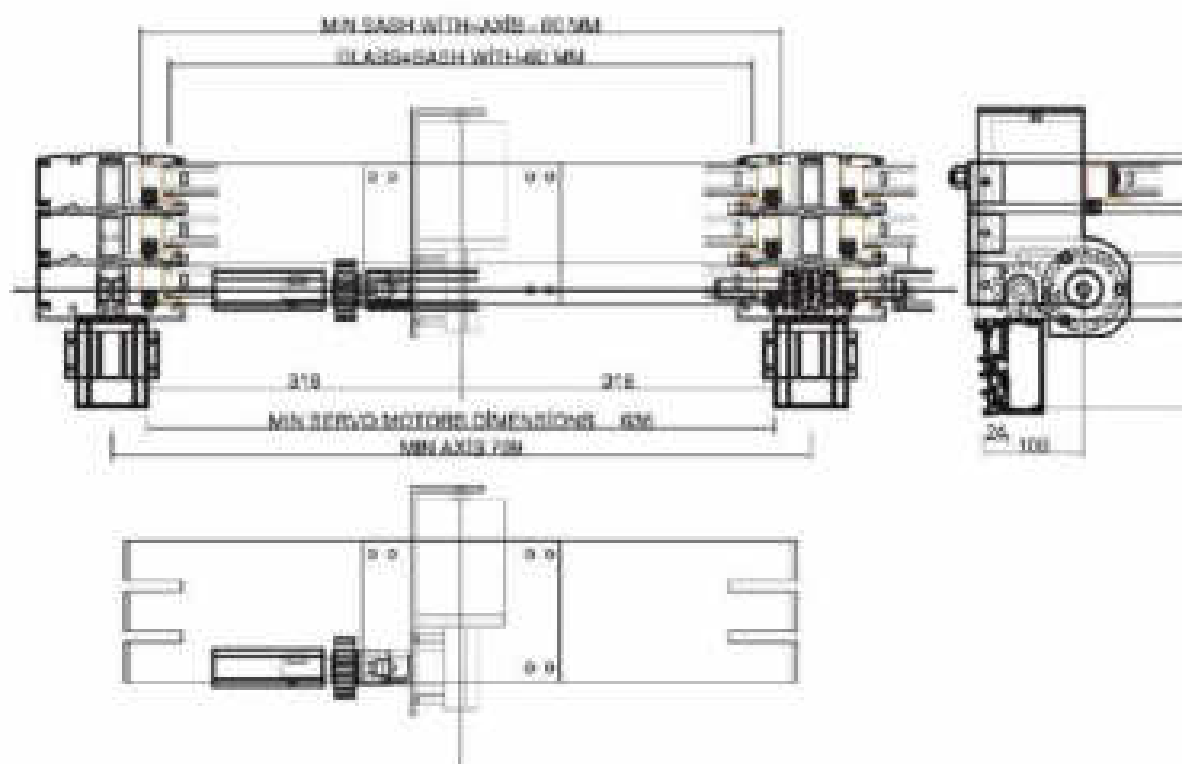

# SRA 150

MOTORIZED GLASS ROOF SYSTEM

ACCURACY

HARMONY

BALANCE

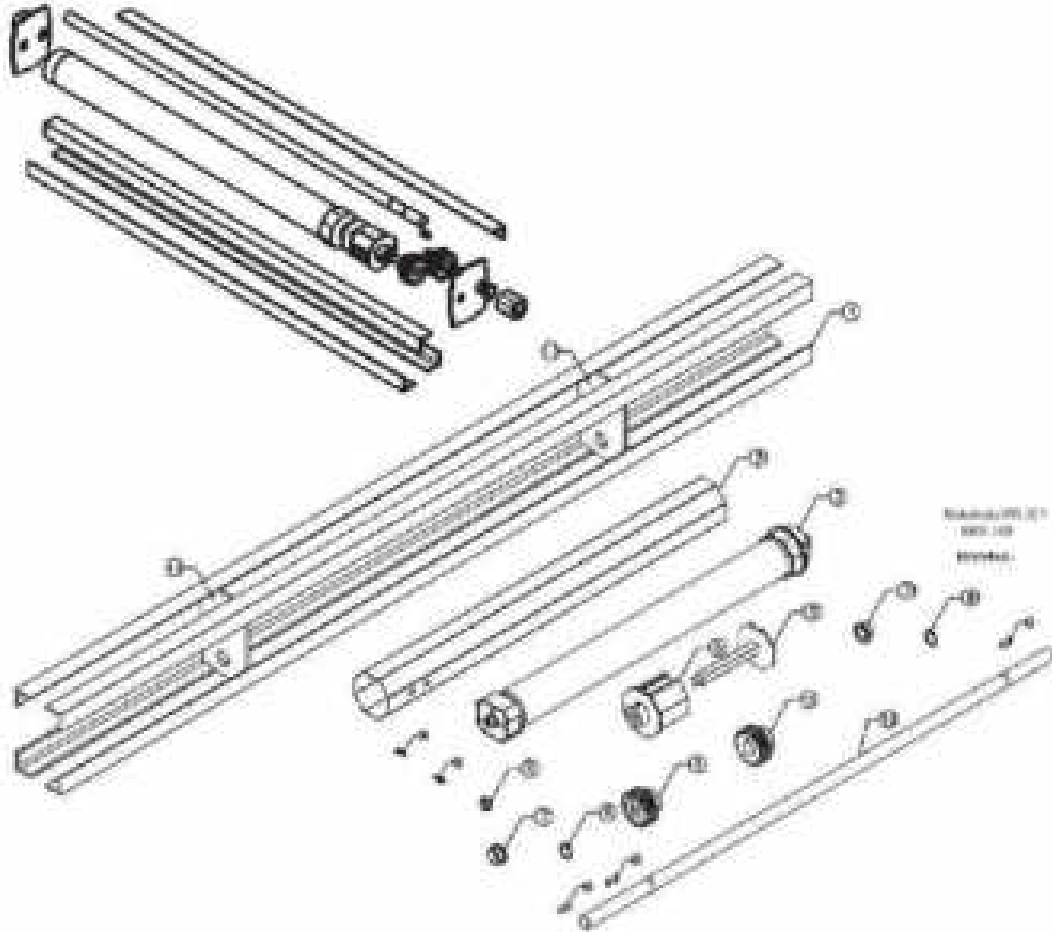

Yazı	İsim	Adet	Malzeme	Stok No
1	Kısa uçlu Alüminyum 1.5m	4	Demir, siyah boyalı	1000481
1.1	Alüminyum kısa uçlu çubuk	1	Demir, siyah boyalı	8010010
1.2	Alüminyum kısa uçlu çubuk	1	Demir, siyah boyalı	8010011
2	Roller (Alüminyum)	1	1.5m Çap, Çık. 270mm	8010100
3	ROCKER Motor	1	110V Güç 11.5kw	8001004
4	Motorun 110V Çıkışı	2	Çelik, galvanizli	1001100
5	Motorun 110V Çıkışı	1	Çelik, galvanizli	8010100
6	Çubuk 1.5m	1	Demir	8001100
7	Çubuk 1.5m	2	Demir	8001101
8	Motorun 110V Çıkışı	1	Demir	8010000
9	Motorun 110V Çıkışı	1	Alüminyum	8000004
10	Motorun 110V Çıkışı	1	Alüminyum	8000002
11	Motorun 110V Çıkışı	2	Demir	8010000
12	Alüminyum	1	Çelik	8010001

# SRA 150

MOTORIZED GLASS ROOF SYSTEM

ACCURACY

HARMONY

BALANCE

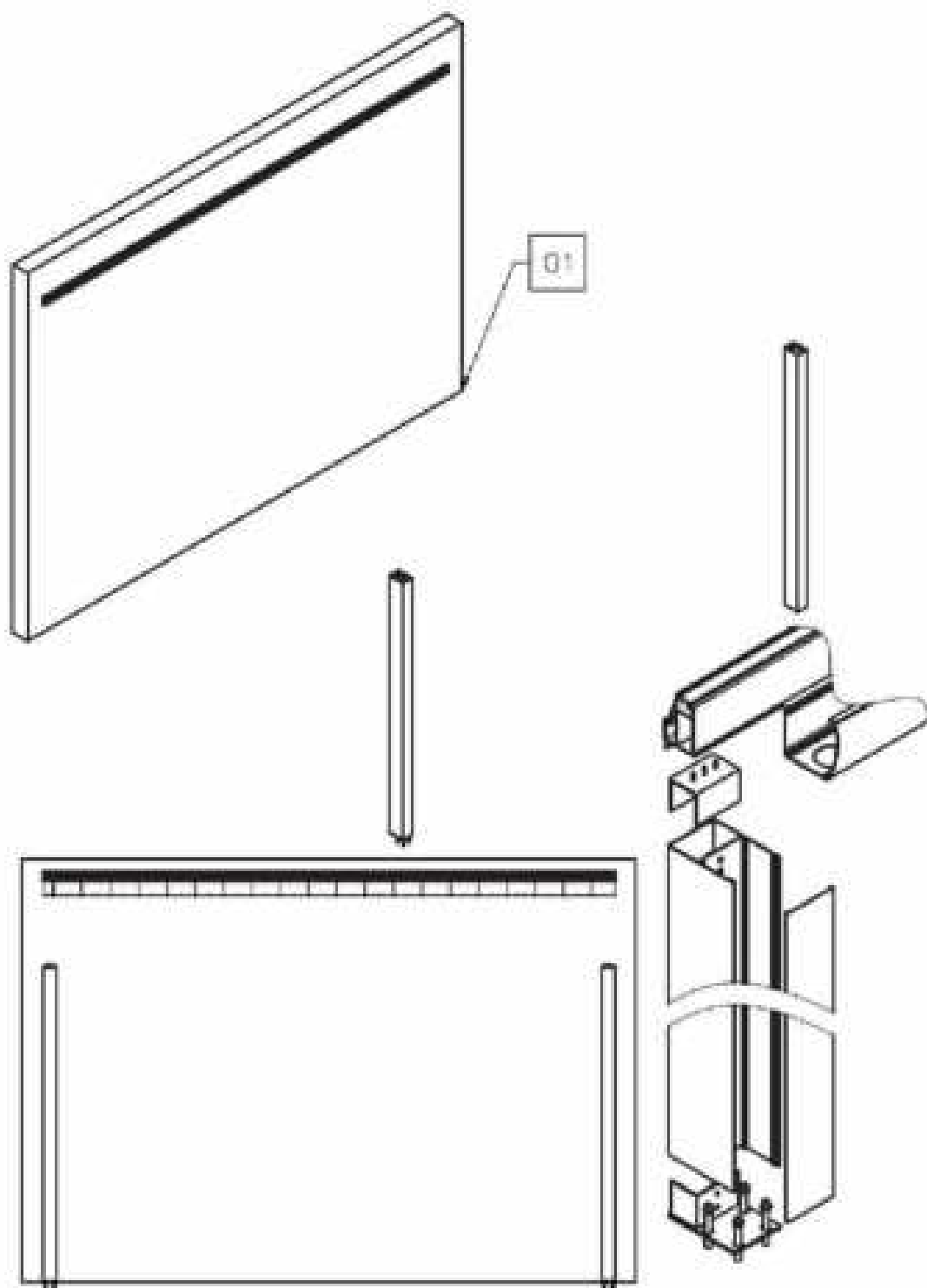

# SRA 150

MOTORIZED GLASS ROOF SYSTEM

ACCURACY

HARMONY

BALANCE

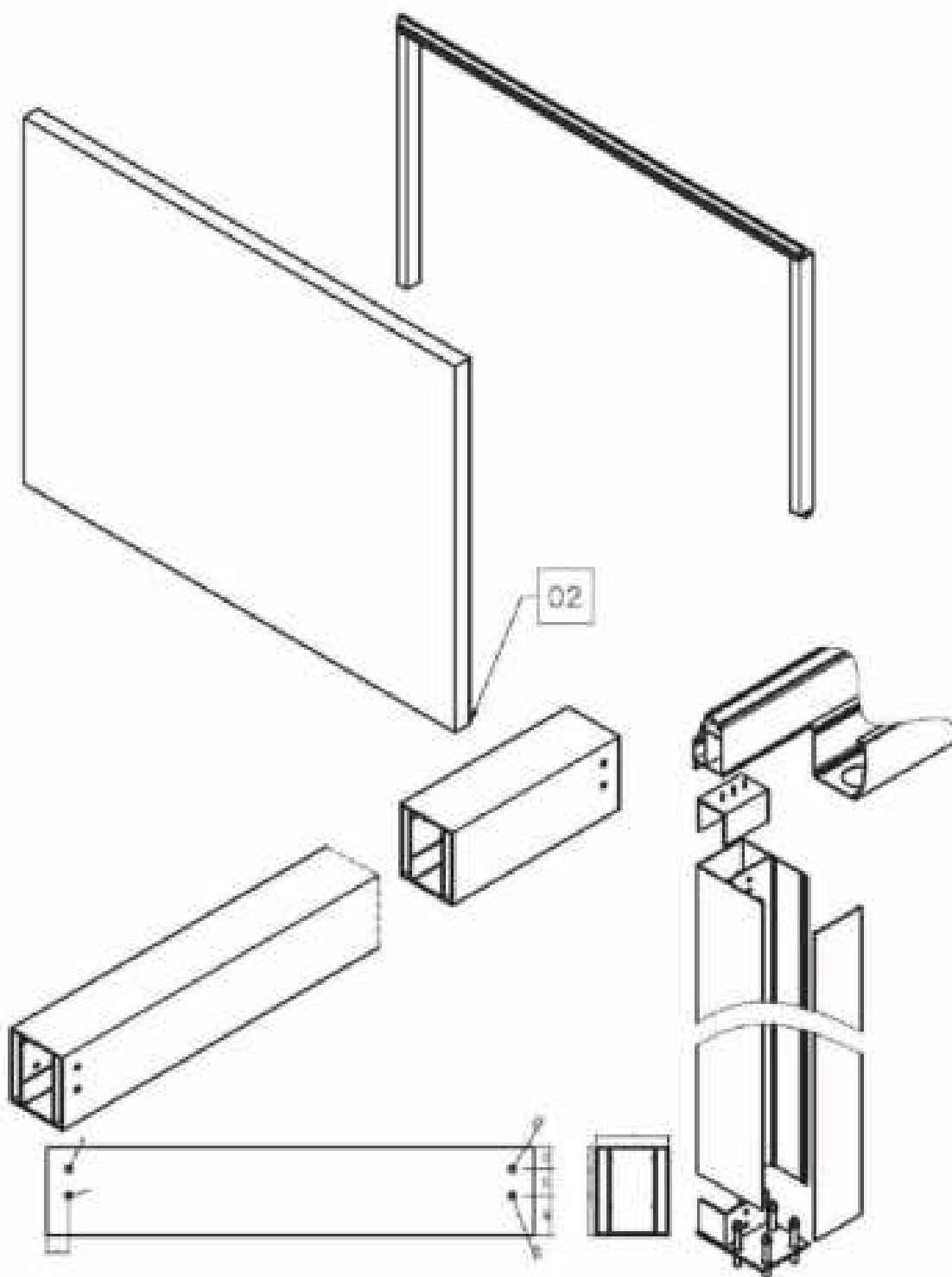

# SRA 150

MOTORIZED GLASS ROOF SYSTEM

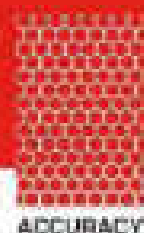

ACCURACY



HARMONY



BALANCE

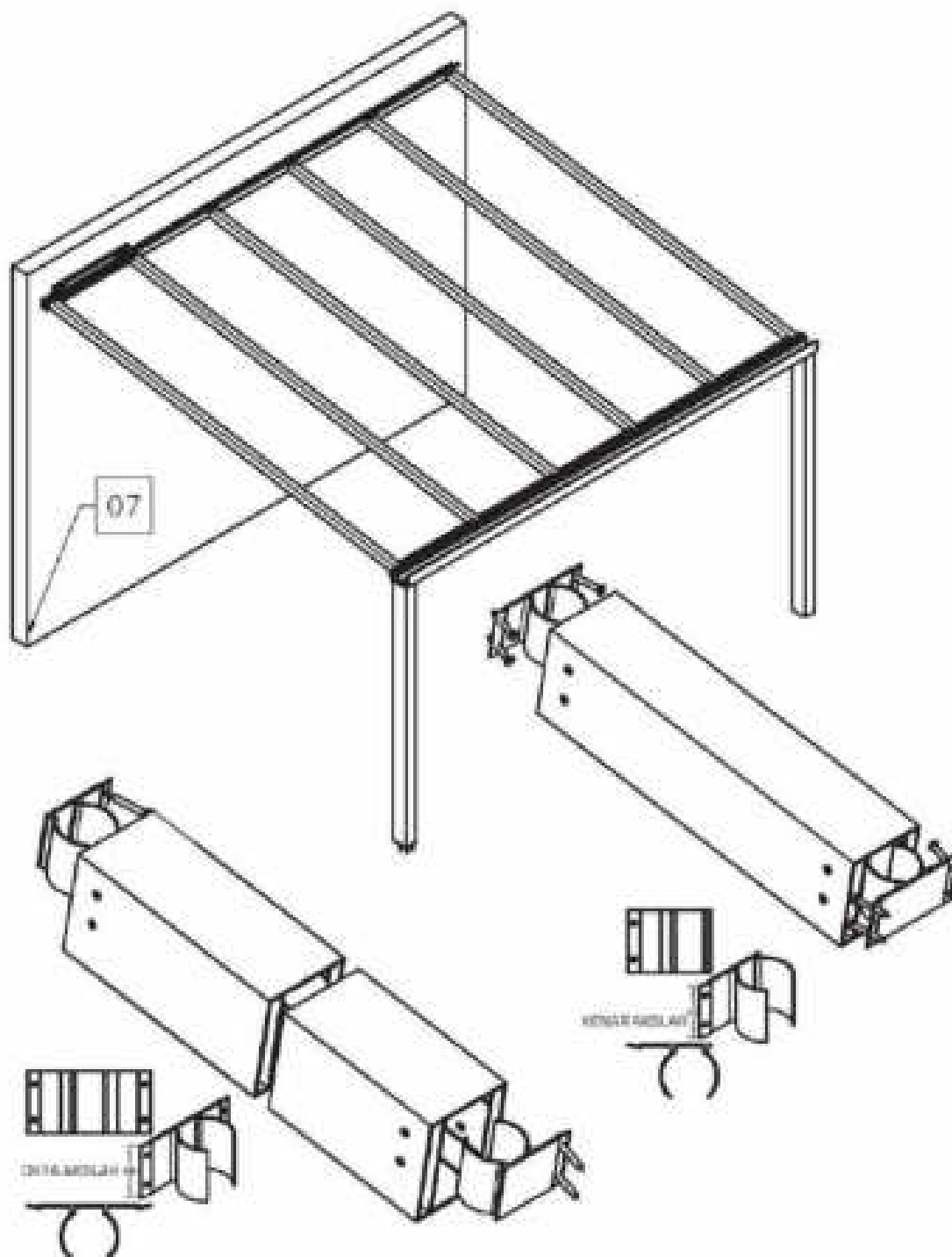



# SRA 150

MOTORIZED GLASS ROOF SYSTEM

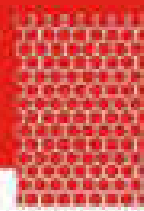

ACCURACY



HARMONY



BALANCE

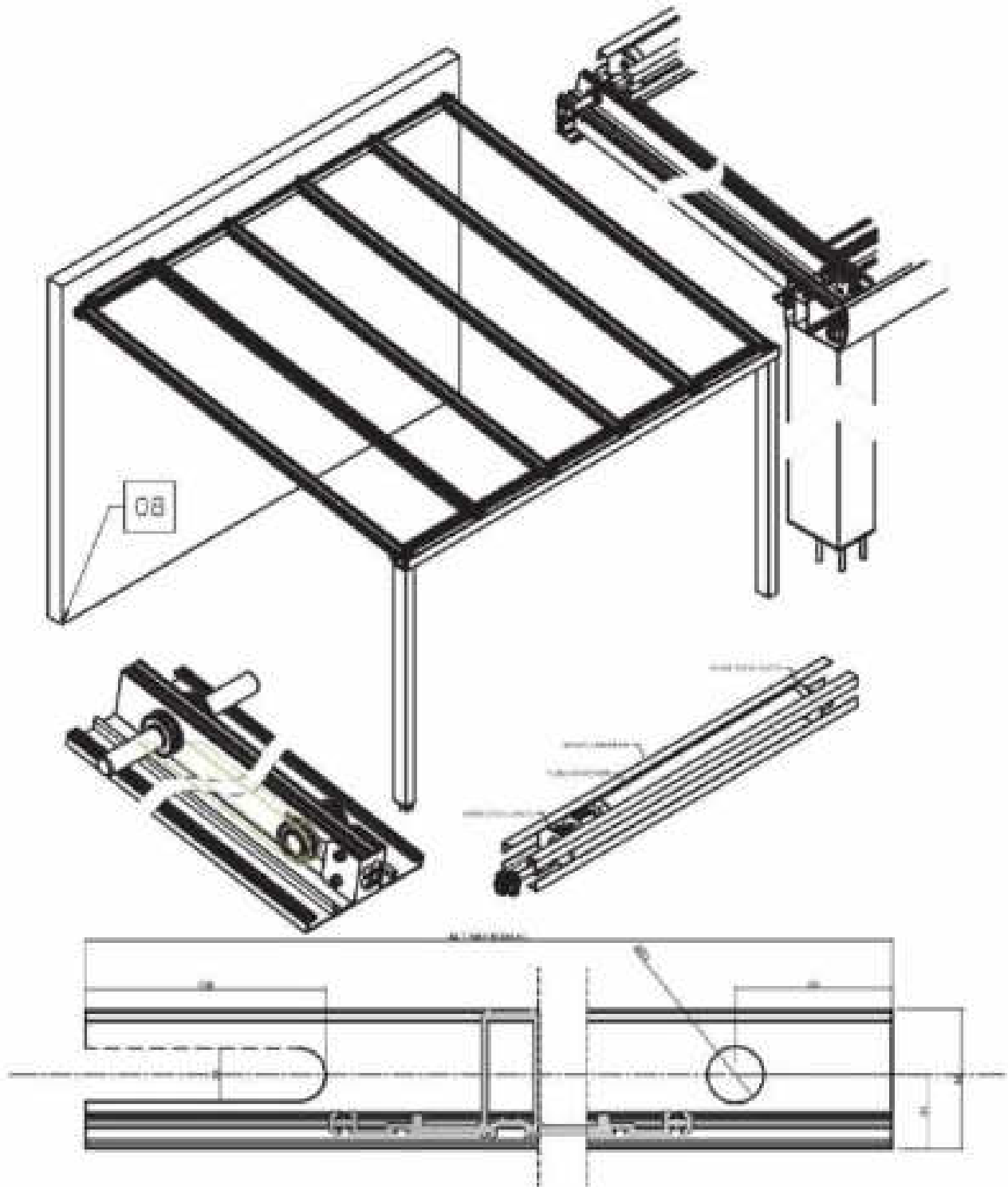

# SRA 150

MOTORIZED GLASS ROOF SYSTEM

ACCURACY

HARMONY

BALANCE

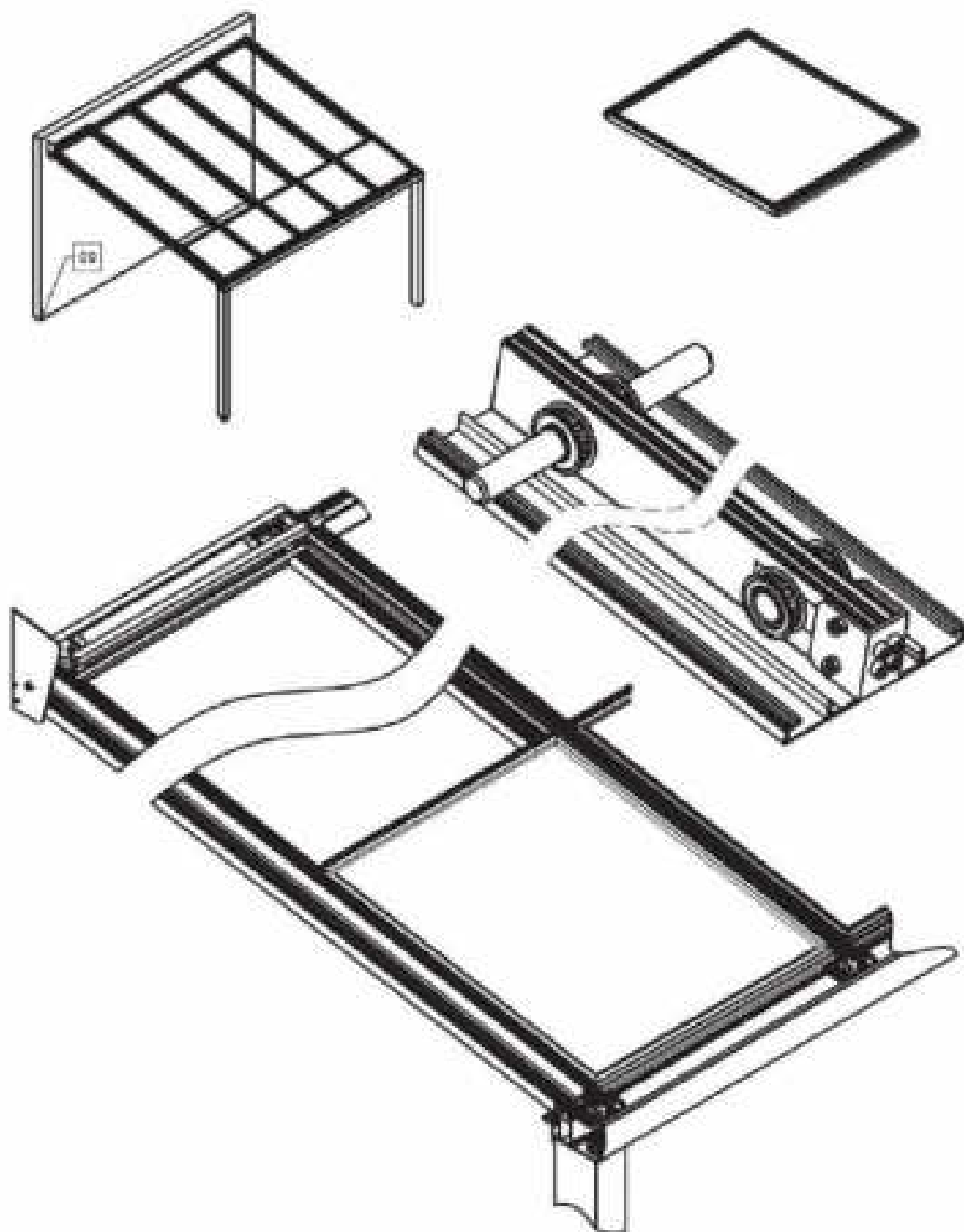

# SRA 150

MOTORIZED GLASS ROOF SYSTEM

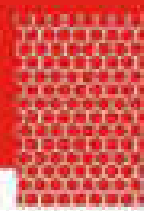

ACCURACY



HARMONY



BALANCE

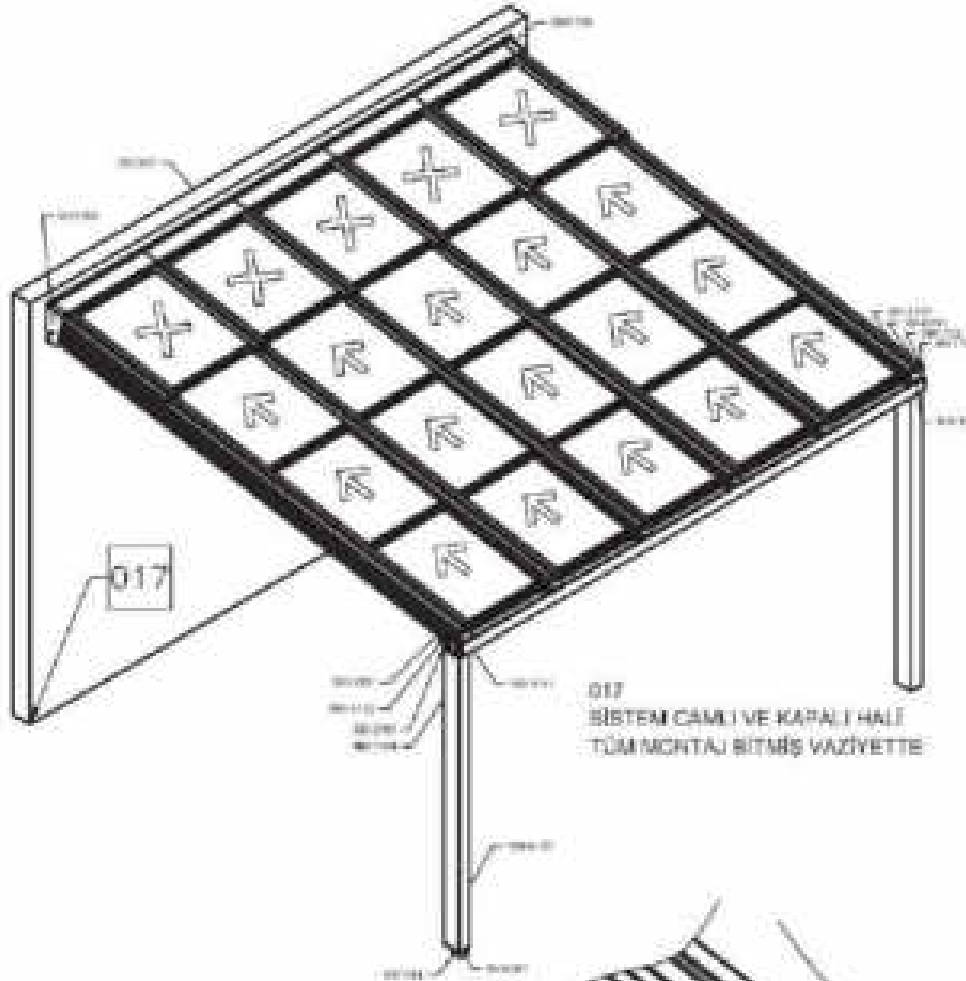

017  
SİSTEM CAMI VE KAPALI HALİ  
TÜM MONTAJ BİTİRMİŞ VAZİYETTE

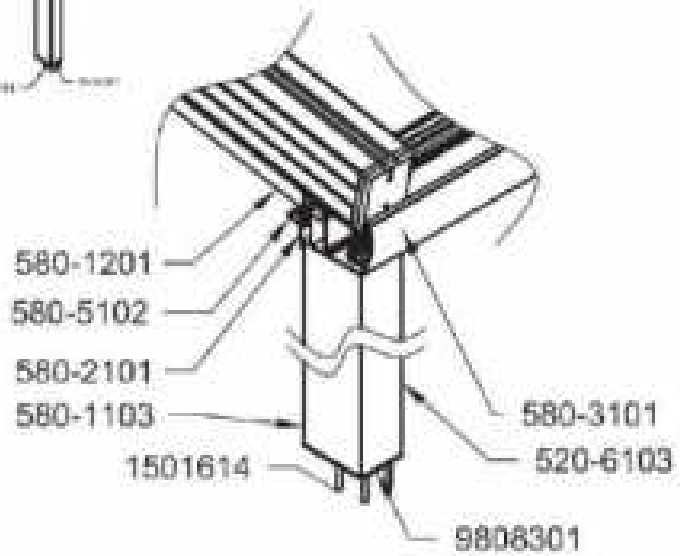

# SRA 150

MOTORIZED GLASS ROOF SYSTEM

ACCURACY

HARMONY

BALANCE

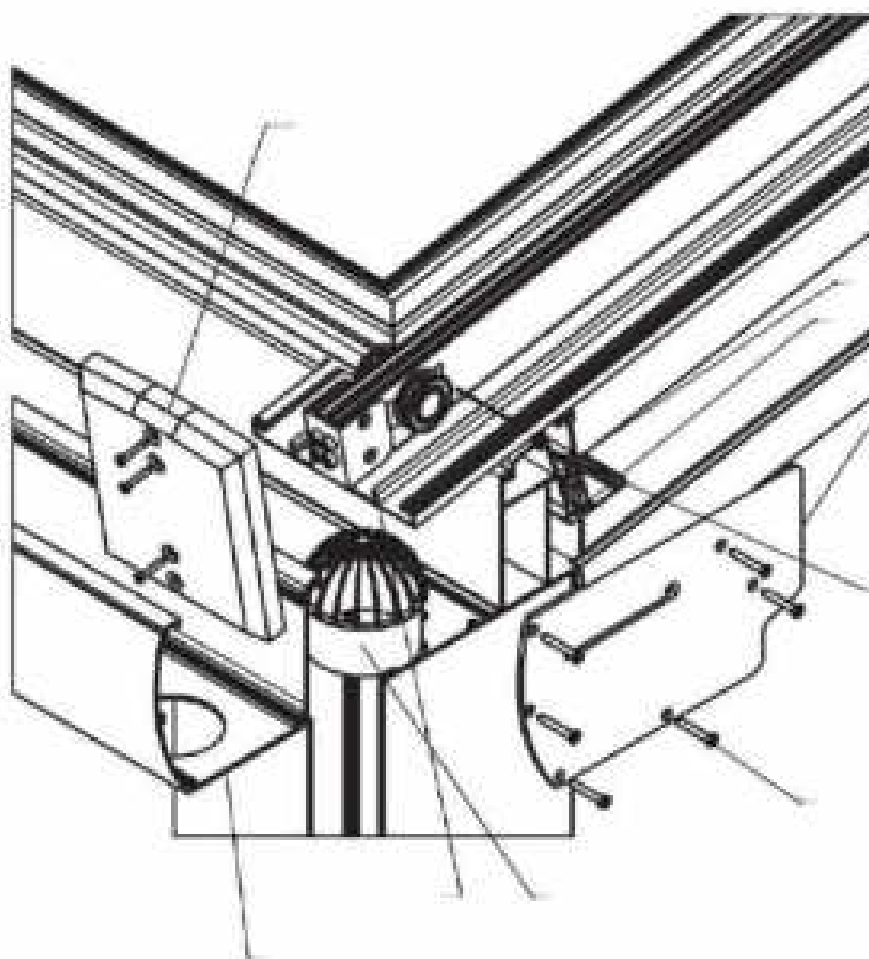
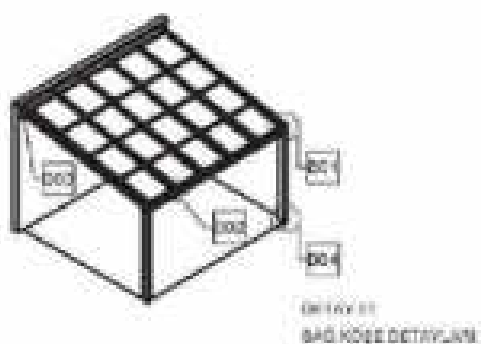

# SRA 150

MOTORIZED GLASS ROOF SYSTEM

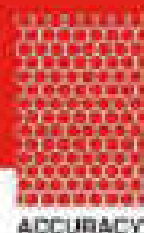

ACCURACY



HARMONY



BALANCE

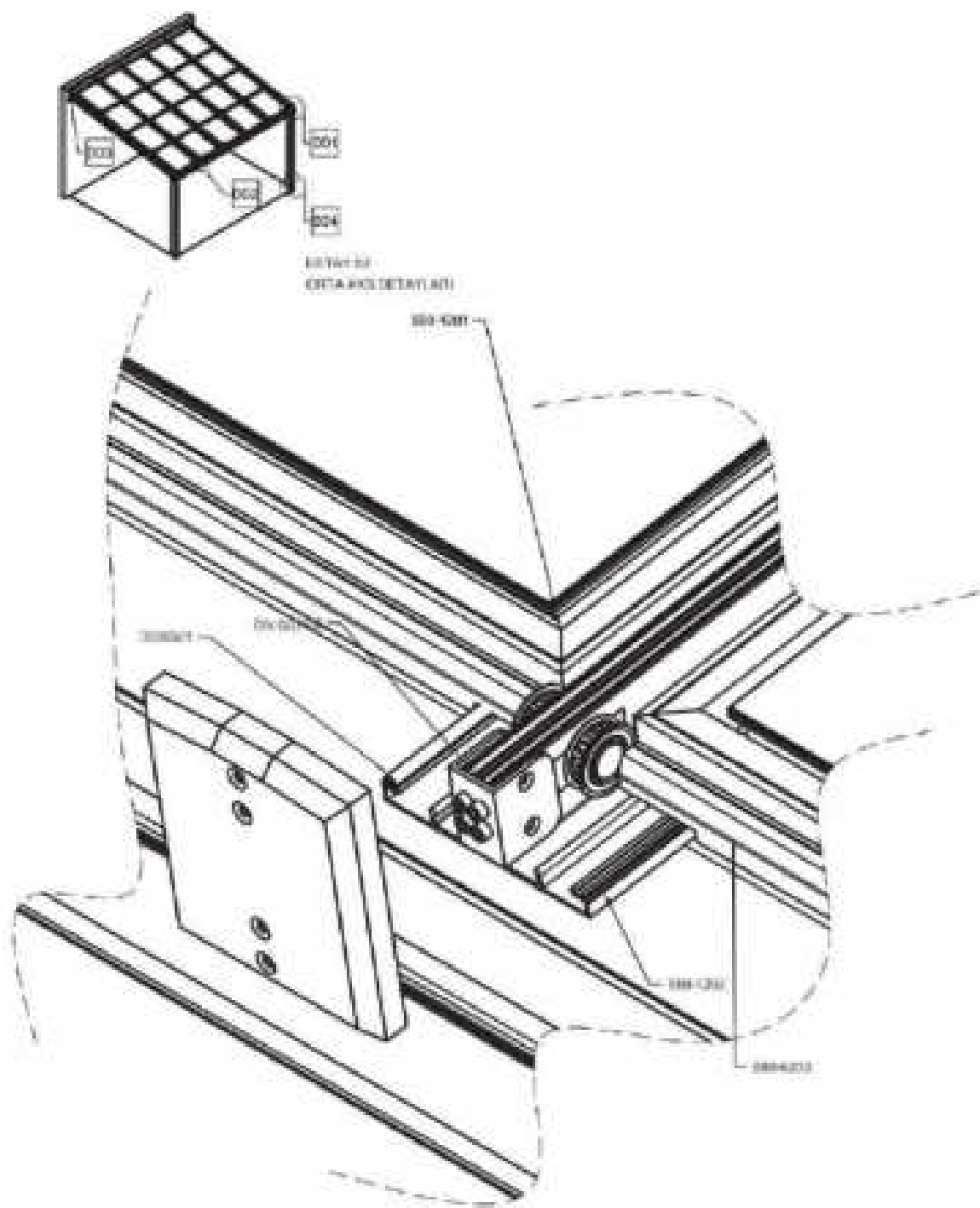

# SRA 150

MOTORIZED GLASS ROOF SYSTEM



ACCURACY



HARMONY



BALANCE

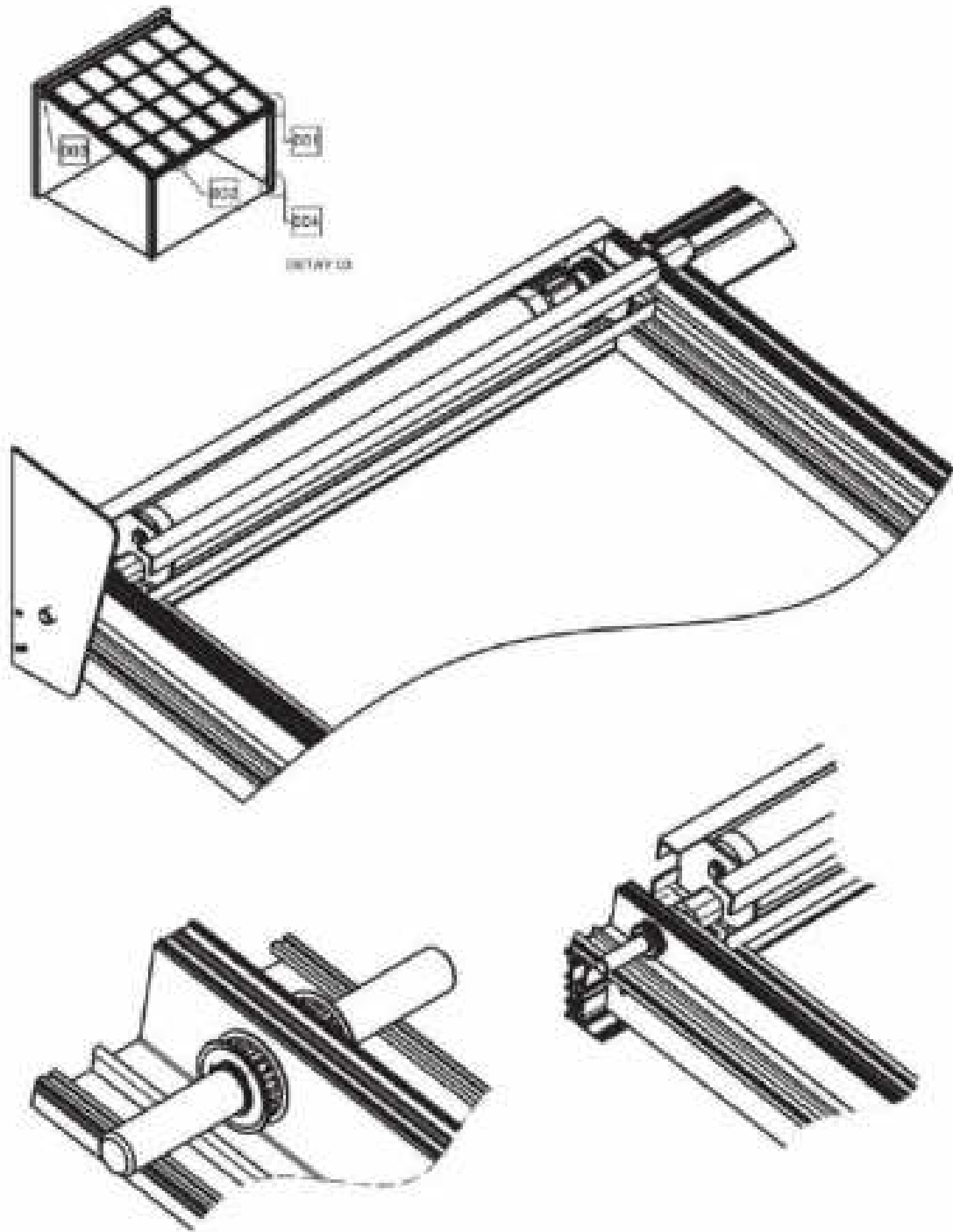

# SRA 150

MOTORIZED GLASS ROOF SYSTEM

ACCURACY

HARMONY

BALANCE

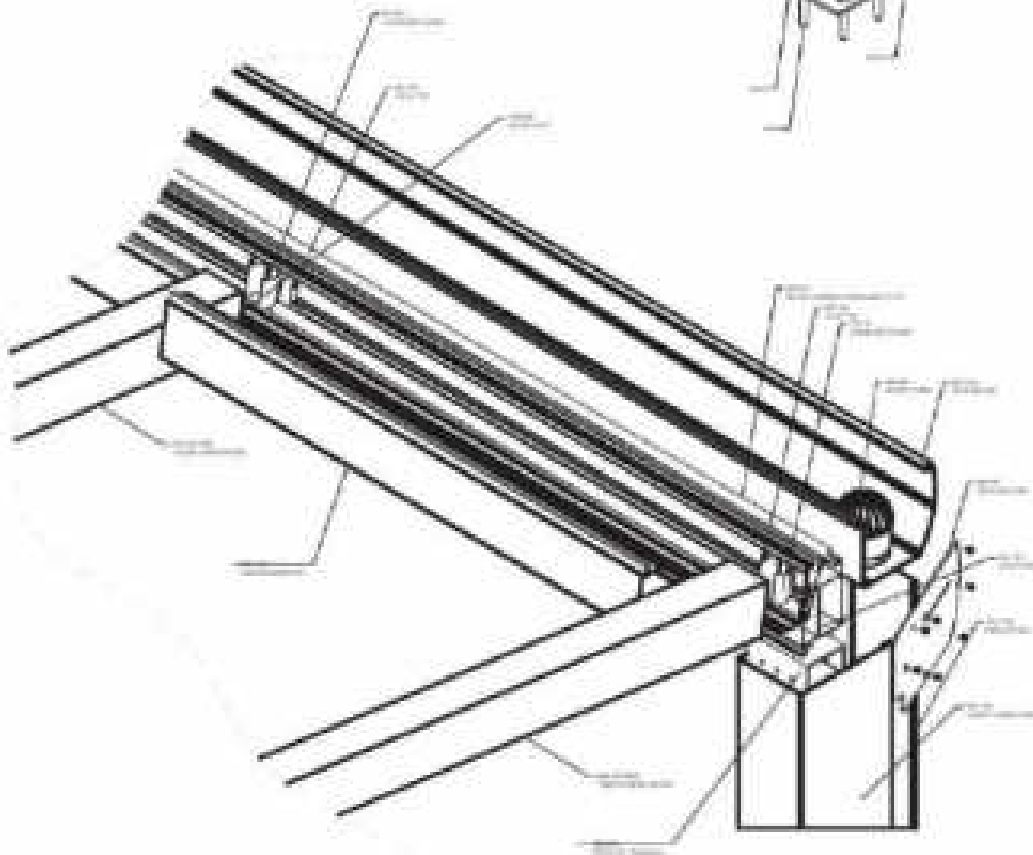
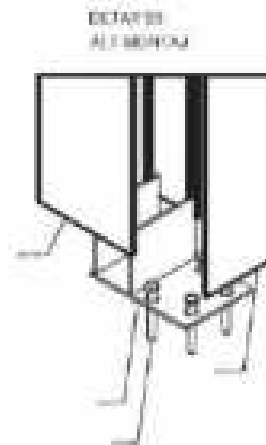
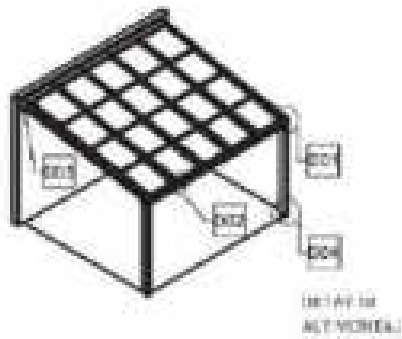

# SRA 150

MOTORIZED GLASS ROOF SYSTEM

ACCURACY

HARMONY

BALANCE

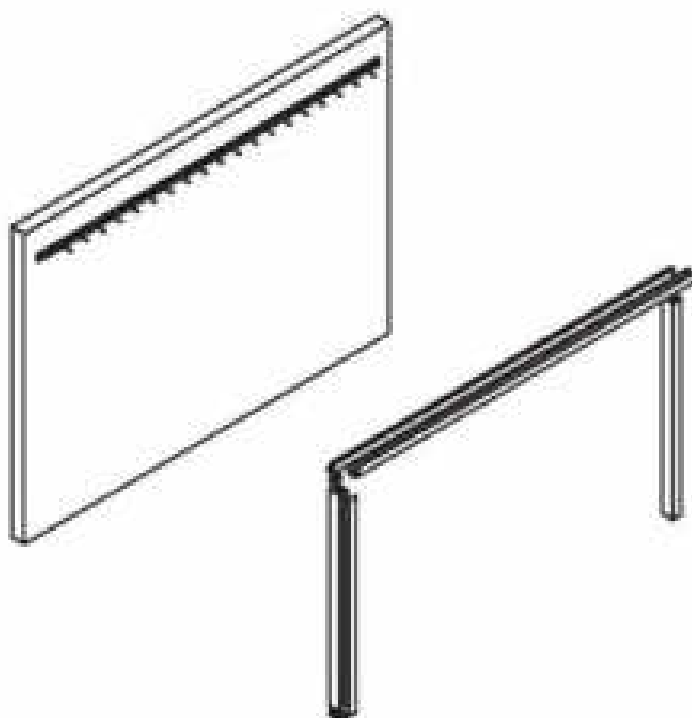
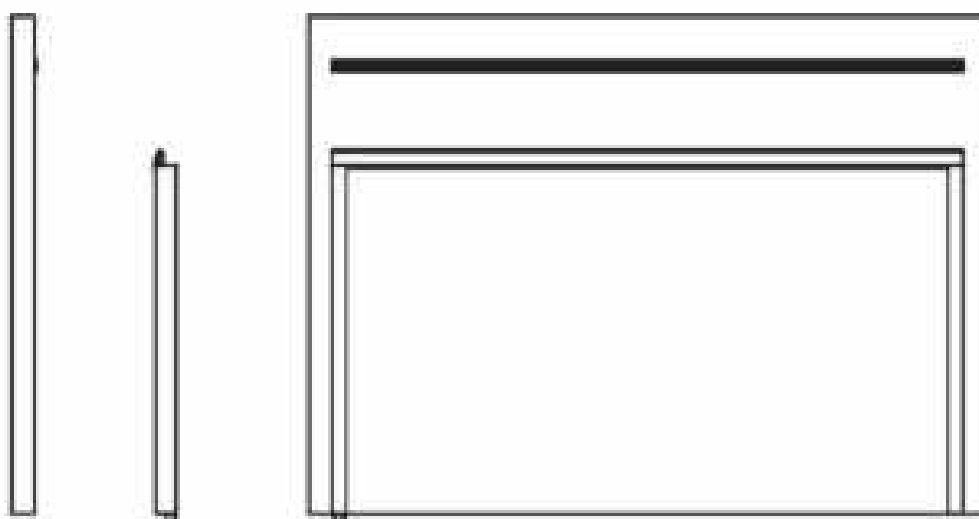



# SRA 150

MOTORIZED GLASS ROOF SYSTEM

ACCURACY

HARMONY

BALANCE

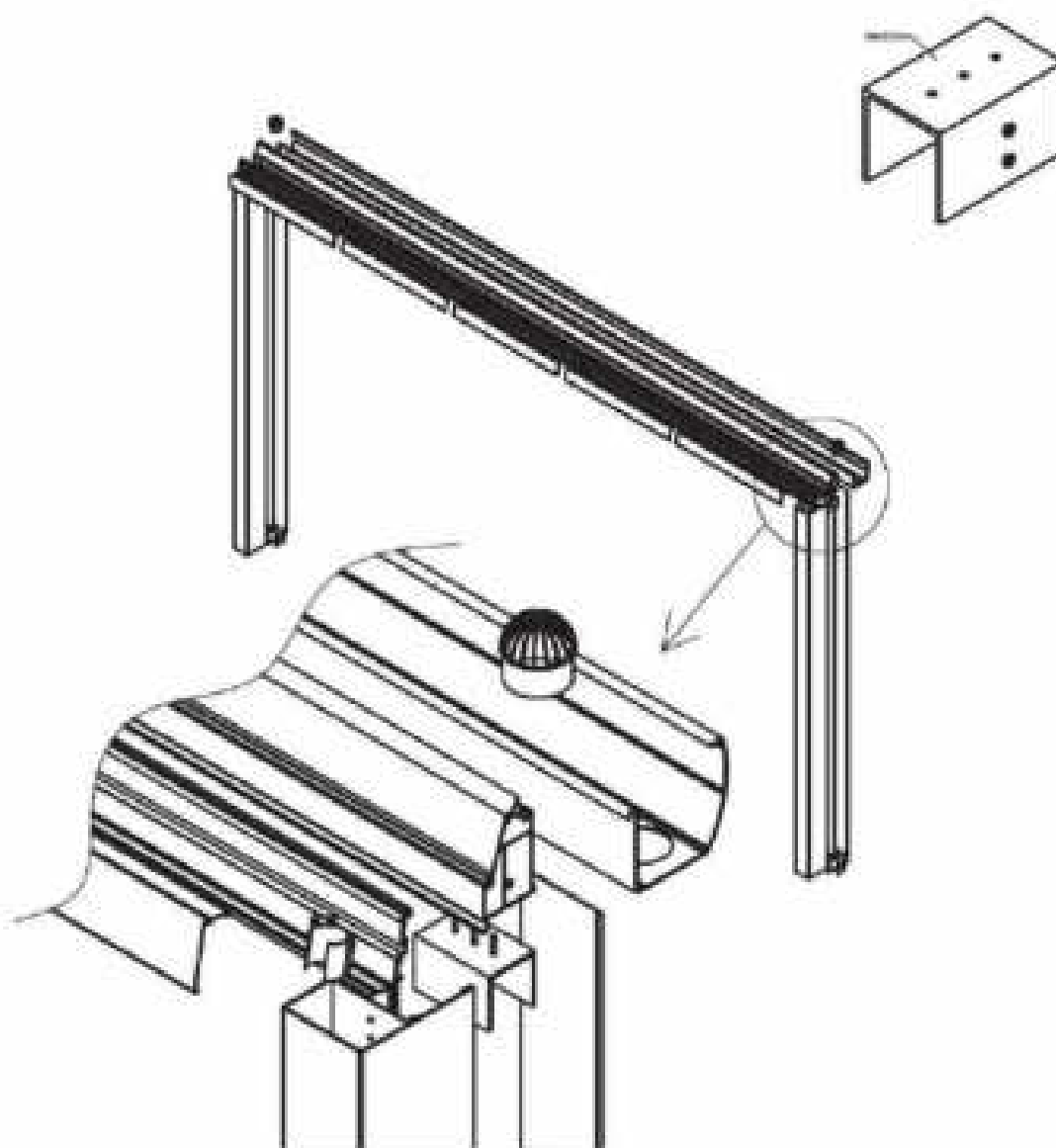

# SRA 150

MOTORIZED GLASS ROOF SYSTEM

ACCURACY

HARMONY

BALANCE

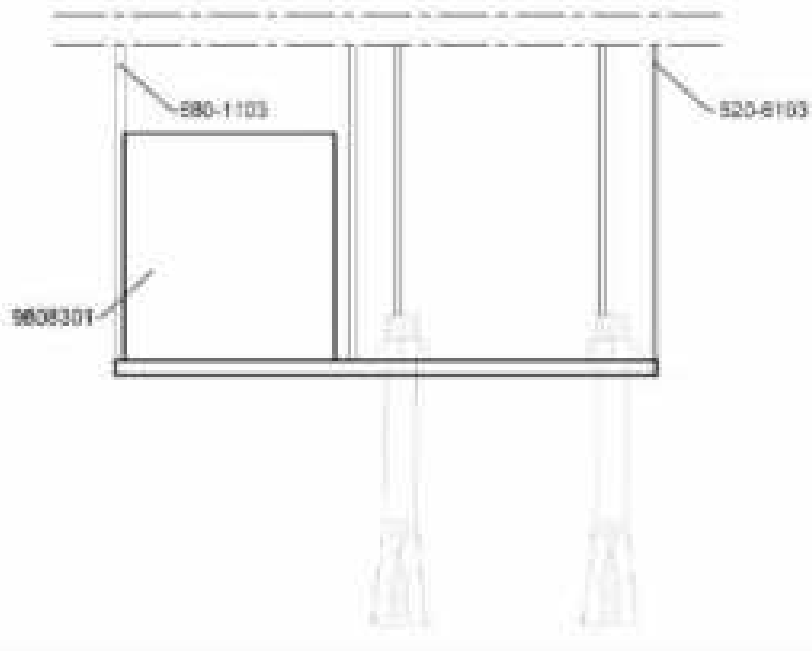
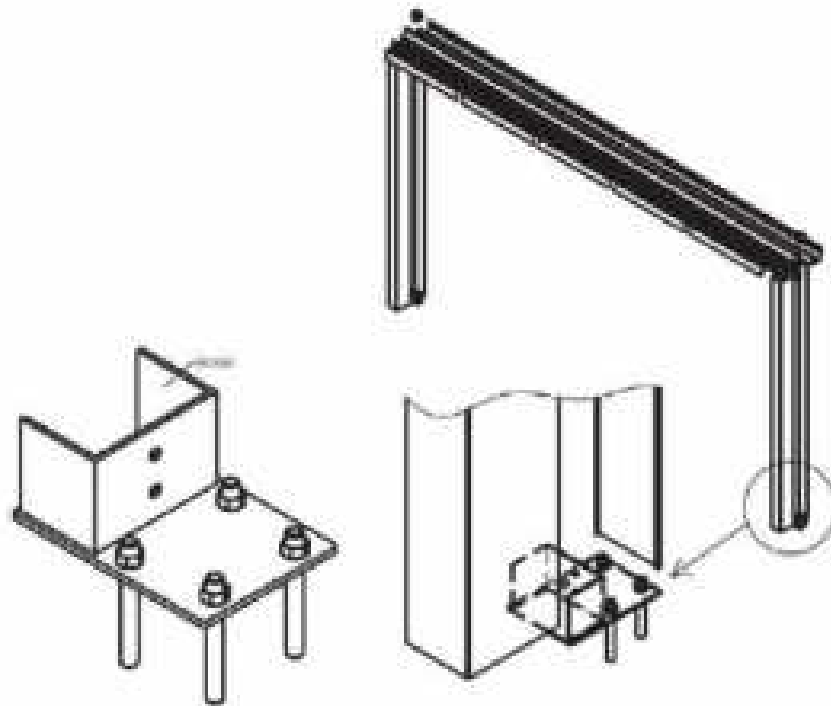

# SRA 150

MOTORIZED GLASS ROOF SYSTEM

ACCURACY

HARMONY

BALANCE

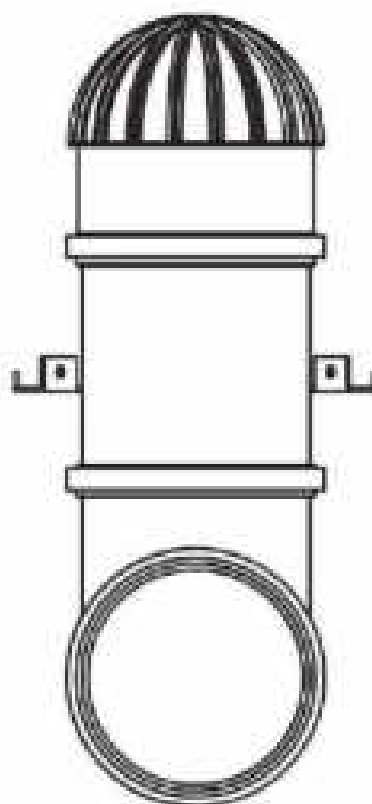
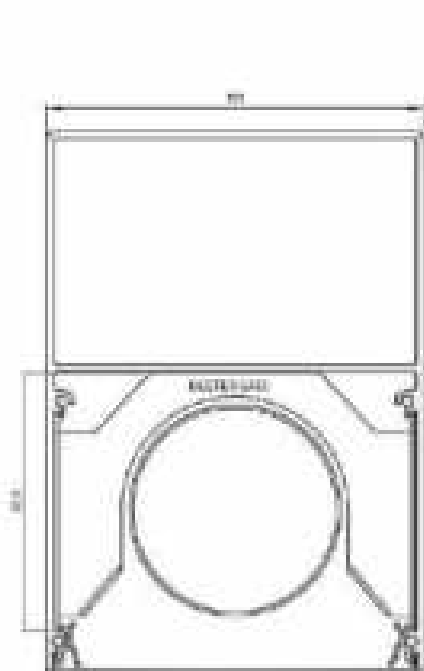

# SRA 150

MOTORIZED GLASS ROOF SYSTEM

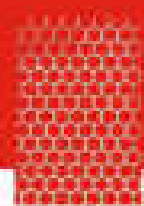

ACCURACY

HARMONY

BALANCE



# SRA 150

MOTORIZED GLASS ROOF SYSTEM

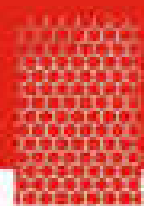

ACCURACY

HARMONY

BALANCE



# SRA 150

MOTORIZED GLASS ROOF SYSTEM



ACCURACY

HARMONY

BALANCE

